

Subject: Pulsar III Quick Change Filter Assembly Installation Instructions

Removal of filter and old system:

- Removal of dust collector access door
 - Remove the retaining knob at the bottom of the door.
 - Swing the bottom of the door away from the dust collector access opening.
 - Lift the door off the top support angle.
- The filter cartridge is secured with a twist-to-release 3-lug top cap. Loosen the tensioning knob enough to rotate the filter cartridge to the right to release it from the two rear shoulder screws, but do not release the cartridge from the mounts at this time.
- From the bottom of the filter cartridge, slide a suitable plastic trash bag over the cartridge to contain dust.
- Rotate the cartridge to the right to remove the lug slots from the rear shoulder screws and tensioning knob, and then remove the cartridge from the dust collector access door.
- Retain the filter for reinstallation or discard if installing a new filter.
- Remove the mounting shoulder screws from the top mounting plate.
- Remove remaining dust from the top mounting plate and clean surface.
- Check/clean the threads to make installation easier. Use a 3/8-16 tap if needed.

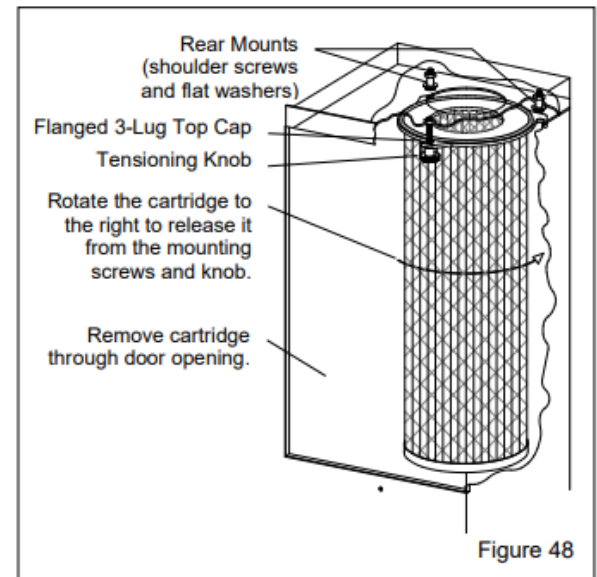

Installing the Assembly into the Dust Collector

Caution – Assembly is heavy

- Position the assembly (item #1) inside the dust collector through the access door. The Filter Clamp Front Bar (item #2) needs to be positioned closest to the access door.
- With the assembly in position, start threading the closest bolt to you so that the assembly is supported during the rest of the installation. Next start the back bolts and snug the assembly to the mounting plate.

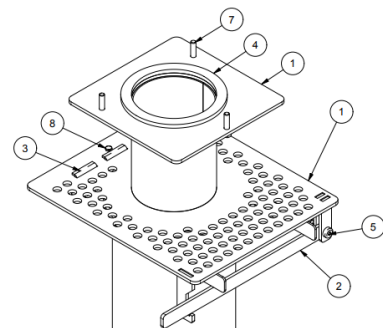

- Tighten the bolts in a clockwise pattern so that they compress the gasket uniformly.

Installing the Filter Cartridge

- Rest the lip of the filter onto the two bars facing you at an angle.
- Raise the bars and filter into place with the Front Clamp Bar, being sure to keep the filter's gasket centered around the hole in the assembly.
- Lock the bar into place on the opposite end hook.
- Reinstall the access door.

Verify the tightness of all hardware after the first 40 hours of use

Dust Bin Gasket Placement

- When installing the dust bin gasket to the underside of the collector, align the front of the gasket to the front of the mount. The notches must be on the front left and right rear corners. Proper alignment of the gasket will allow the interlock to engage.