

**APOLLO LP SERIES
SUPPLIED-AIR RESPIRATOR
Low Pressure 8 psi to 20 psi
O. M. 29791**

DATE ISSUED 12/02/20
REVISION: A

 **WARNING**

Do not use this equipment before **READING this **MANUAL** and **UNDERSTANDING** its contents.**

These **WARNINGS are included for the health and safety of the operator and those in the immediate vicinity. Failure to read and understand these warnings can result in injury or death.**

Electronic files include a preface containing the same important information as in the orange cover.

NOTICE

This supplied air respirator conforms to all NIOSH specifications and standards and carries NIOSH approval. As manufactured, this respirator complies only with those foreign approvals that accept NIOSH certification. Specifically, it has not been manufactured to European CE standards and does not carry the European CE mark.

© 2020 CLEMCO INDUSTRIES CORP.
ONE CABLE CAR DR.
WASHINGTON, MO 63090
Phone (636) 239-4300
Fax (800) 726-7559
Email: info@clemcoindustries.com
www.clemcoindustries.com



1.0 INTRODUCTION

1.1 Scope of Manual

1.1.1 This manual covers setup, operation, maintenance, and replacement parts for the following Clemco Apollo LP (low pressure) Series Supplied-Air Respirator Models:

- Apollo 20 LP
- Apollo 600 LP

1.1.2 Read this entire manual and all accessory manuals before setting up or using the respirator. The following Clemco manuals are available for accessories that may be used with Apollo LP Respirators. They are available on our website: www.clemcoindustries.com. Refer to Figure 2 for a typical setup.

Description	Manual No.
CALIPSO Ambient Air Pump	25920

1.2 Safety Alerts

1.2.1 Clemco uses safety alert signal words, based on ANSI Z535.4-2011, to alert the user of a potentially hazardous situation that may be encountered while operating this equipment. ANSI's definitions of the signal words are as follows:



This is the safety alert symbol. It is used to alert you to potential physical injury hazards. Obey all safety messages that follow this symbol to avoid possible injury or death.

NOTICE

Notice indicates information that is considered important, but not hazard-related, if not avoided, could result in property damage.

CAUTION

Caution indicates a hazardous situation that, if not avoided, could result in minor or moderate injury.

WARNING

Warning indicates a hazardous situation that, if not avoided, could result in death or serious injury.

DANGER

Danger indicates a hazardous situation that, if not avoided, will result in death or serious injury.

1.3 Table of Contents

SUBJECT	SECTION LOCATION
Introduction	1.0
Scope of Manual	1.1
Safety Alerts	1.2
Table of Contents	1.3
NIOSH Approval Number 19C-358	1.4
OSHA Regulations	1.5
Respiratory and Health Alerts - Toxic Dust Poisoning ..	1.6
Cautions and Limitations	1.7
S – Special or Critical User's Instructions	1.8
Protection Factors	1.9
INSPECTION	2.0
Component Checklist	2.1
PREPARATION	3.0
Adjust Web Suspension	3.1
Prepare Lens System	3.2
Attach Breathing Tube Assembly	3.3
Prepare Respirator Air-Supply Hose	3.4
AIR SUPPLY	4.0
Air Quality	4.1
Air Volume and Pressure Requirements	4.2
Pressure conversion kit	4.3
OPERATION	5.0
Inspection and Preparation	5.1
Donning (putting on) the Respirator	5.2
Doffing (taking off) the Respirator	5.3
ADJUSTMENTS	6.0
Web Suspensions	6.1
Apollo 20 alternate web suspension	6.1.1
Apollo 600 alternate web suspension	6.1.2
DLX Padded Suspension	6.2
Apollo 20 alternate DLX padded suspension	6.2.1
Apollo 600 alternate DLX padded suspension	6.2.2

MAINTENANCE PROGRAM7.0
 Basic Service7.1
 Inspection7.2
 Cleaning and Disinfecting7.3
 Repairs (service maintenance)7.4
 Storage7.5
 Daily storage7.5.1
 Long-term storage7.5.2

CLEANING AND DISINFECTING8.0
 Cape8.1
 Inner Collar (model 600 only)8.2
 Suspensions8.3
 DLX padded suspension and chin strap8.3.1
 Web suspension and chin strap8.3.2
 Helmet Shell8.4
 Disinfecting8.5

SERVICE MAINTENANCE – APOLLO MODEL 20 ...9.0
 Apollo 20 Lens System9.1
 Replacing Cover and Middle Lenses9.2
 Remove and Replace Inner Lens and Gasket9.3
 Remove and Replace Lens Frame9.4
 Remove and Replace Rubber Window Latch9.5
 Remove and Replace the Cape9.6
 Remove and Replace Suspensions9.7
 DLX padded suspension, standard9.7.1
 Web suspension with sweatband, alternate9.7.2
 Remove and Replace the Chin Strap9.8
 Remove and Replace the Air-Channel Partition9.9



SERVICE MAINTENANCE – APOLLO MODEL 600 .10.0
 Apollo 600 Lens System10.1
 Remove and Replace the Fixed Inner Lens
 and Window Gasket10.2
 Intermediate Lens10.3
 Perforated Outer Lenses10.4
 Rectangular Cover Lens10.5
 Remove and Replace Suspensions10.6
 Web suspension with sweatband10.6.1
 DLX padded suspension10.6.2
 Remove and Replace the Chin Strap10.7
 Remove and Replace the Cape10.8
 Remove and Replace the Inner Collar10.9
 Remove and Replace the Window Frame10.10
 Remove and Replace the Window Latch10.11
 Remove and Replace the Air-Inlet Fitting10.12
 Remove and Replace the Air-Channel Partition10.13

REPLACEMENT PARTS11.0
 Supplied-Air Respirator Systems11.1
 Apollo 20 LP SAR Systems11.1.1
 Apollo 600 LP SAR Systems11.1.2
 Apollo Accessories11.2
 Apollo 20 Accessories11.2.1
 Apollo 600 Accessories11.2.2
 Apollo 20 Respirator Replacement Parts11.3
 Apollo 600 Respirator Replacement Parts11.4

1.4 NIOSH Approval Number 19C-358

1.4.1 Clemco Apollo Supplied-Air Respirators are approved by the National Institute of Occupational Safety and Health (NIOSH).

1.4.2 The NIOSH label shown below lists the Apollo Respirator approval number. An X on the approval line indicates which components are approved for the specific respirator. Do not use any nonapproved components with this respirator.

		Clemco Industries Corp.					
		Washington MD, USA (636) 239-0300					
TYPE C AND CE CONTINUOUS FLOW SUPPLIED-AIR RESPIRATOR IS APPROVED ONLY IN THE FOLLOWING CONFIGURATIONS:							
TC#	Protector	Part No	RESPIRATOR COMPONENTS				Cautions and Limitations
			Helmets	Control Valves	Air Hoses	Accessories	
		Model					
		Apollo 600					
		Apollo 20					
			CF/Low Pressure		Black 1/2" X 100 Ft.	Conversion Kit, Apollo	
					Black 1/2" X 50 Ft.	Helmet LP To HP	
			21777		21413	22080	
					22510		
19C-358	CF/SA/SB	Apollo LP Series	x	x	x	x	ABCDEJMNOS
1 PROTECTION							
CF-Continuous Flow SA - Supplied-air SB- Supplied Air Abrasion Blasting							
2 CAUTIONS AND LIMITATIONS							
A- Not for use in atmospheres containing less than 19.5 percent oxygen.							
B- Not for use in atmospheres immediately dangerous to life or health							
C- Do not exceed maximum use concentrations established by regulatory standards							
D- Air-line respirators can be used only when the respirators are supplied with respirable air meeting the requirements of CGA-7.1 Grade D or higher quality							
E- Use only the pressure ranges and hose lengths specified in the user's instructions							
J- Failure to properly use and maintain this product could result in injury or death							
M- All approved respirators shall be selected, fitted, used, and maintained in accordance with MSHA, OSHA, and other applicable regulations.							
N- Never substitute, modify, add, or omit parts. Use only exact replacement parts in the configuration as specified by the manufacturer.							
O- Refer to users instructions, and/or maintenance manuals for information on use and maintenance of these respirators.							
S- Special or critical users instructions, and/or specific use limitations apply. Refer to instruction manual before donning.							

⚠ WARNING

NIOSH approval applies only when this supplied-air respirator is used as a complete system. Do not make any nonapproved modification, deletion, or substitution. Nonapproved components void the NIOSH approval and may permit ingress of toxic and hazardous dust, resulting in toxic poisoning and respiratory disease.

1.5 OSHA Regulations

1.5.1 OSHA Regulation 29 CFR 1910.134 for respiratory protection in General Industry is referenced throughout this document. Respiratory protection

standards for Construction 29 CFR 1926.103 and for Maritime 29 CFR 1915.154, 1917, and 1918 refer back to 1910.134. The complete regulation is available through the U.S. Dept. of Labor website at www.osha.gov.

1.5.2 Before occupational use of this respirator, a written respiratory protection program must be implemented that meets all local government requirements. In the United States, employers must comply with OSHA 29 1910.134, which includes medical evaluation, training, and fit testing.

1.5.3 It is essential that the user be properly instructed in the use and maintenance of the respirator. This manual must be made available to all users of the respirator, and the users must demonstrate their understanding of its subject matter. Read the entire manual before installing or operating the equipment.

1.5.4 The respirator must be supplied with respirable air that meets requirements described herein. It is the responsibility of the employer to provide quality breathing-air to the respirator and to establish a program to ensure that the respirator is properly used and maintained.

1.6 Respiratory and Health Alerts

WARNING

TOXIC DUST POISONING

Research by the National Institute For Occupational Safety and Health (NIOSH) has discovered risks associated with dust produced during abrasive blasting operations (including but not limited to lead, silica, antimony, arsenic, beryllium, cadmium, chromium, cobalt, nickel, tin, nitrate and nitrite) to unprotected abrasive blasting operators and other personnel who may be exposed to toxic dust in the abrasive blasting vicinity. These risks include debilitating lung, blood, liver, kidney, skin injuries, and even death. Toxic dust is produced primarily by the breakdown of the abrasive being used and the surface being treated during abrasive blasting.

The breakdown of toxic coatings and hazardous abrasive causes the contaminants to become airborne. Breathing toxic dust generated by the abrasive or surface being treated can cause health and life-threatening toxic poisoning and can damage vital organs. Breathing hazardous dust produced from silica and other abrasives

can cause delayed life-threatening respiratory disease.

Prior to blasting, it is imperative that blasting contractors identify all material being removed by blasting and also to obtain safety data sheets (SDSs) for the blasting abrasive. It is the responsibility of the employer to identify all airborne contaminants in the blast vicinity and to ensure they do not exceed the permissible exposure limit (PEL) Ref. 29 CFR 1910.1000 and 29 CFR 1926.62. Thorough site hazard examinations should be made by a certified industrial hygienist, certified safety professional or other qualified professional to identify all contaminants generated by blasting and in the blasting vicinity.

Exposure to dangerous levels of toxic or hazardous dust is not restricted to blast operators. There may be an equal or greater danger present after the blasting process due to lingering airborne dust particles and especially from dust generated during cleanup activity. Heavy-metal paint, asbestos, sand or other silica, and other toxic material dusts will cause serious lung disease or death if not prevented through the use of properly designed and maintained NIOSH-approved, supplied-air respirators worn by blasting operators and all personnel within the work area. OSHA's regulations found primarily in 29 CFR 1910, Subpart Z provides the permissible exposure limits for all toxic and hazardous substances. It is the responsibility of the employer to determine the inhalation hazards associated with the abrasive blasting being performed. Do not begin any operations, including abrasive blasting, without being trained by the employer and fully understanding the hazards associated with the work performed.

The Apollo Supplied-Air Respirator System is approved by NIOSH as a Type-CE, continuous-flow, abrasive blast, supplied-air respirator, in accordance with title 42 CFR Part 84. The NIOSH-recognized assigned protection factor (APF) for any supplied-air respirator equipped with a loose-fitting hood or helmet and operated in a continuous-flow mode is 25, based upon the NIOSH Respirator Decision Logic (Pub. No. 87-108). In other words, any Type-CE respirator should be used only in atmospheres in which the contaminant level does not exceed 25 times the permissible exposure limit. However, OSHA

revised its existing Respiratory Protection standard in 2006 to add APFs and Maximum Use Concentration (MUC) provisions. APF means the workplace level of respiratory protection that a respirator or class of respirators is able to provide to workers. OSHA placed a table reflecting the appropriate APF for various respirators in 29 CFR 1910.134(d)(3)(i)(A). OSHA also provides a free publication titled "Assigned Protection Factors" (reference number "OSHA 3352-02 2009") to assist the user and their employer in understanding the selection of respirators based on APFs and MUCs. This section of the OSHA regulations allow the employer to assign an APF of 1000 to all Apollo Series Respirators based on the simulated workplace protection factor studies Clemco has performed. These studies are available for download from Clemco's Website at www.clemcoindustries.com, under the "Safety Info" tab.

The employer must provide and maintain appropriate approved respirators, in addition to providing operator training and employing required worksite safety practices.

To avoid any potential danger of respiratory injury, approved, supplied-air respirators must be worn at all times in the presence of any type of dust. The respirator must be maintained as described herein. Improper use of any respirator may cause life threatening respiratory disease and immediate poisoning from toxic dust. Respirators should be removed only after the ambient air has been tested with a dust monitor and found to be safe to breathe.

Toxic dust poisoning also may occur by eating, drinking, or smoking in a contaminated area, or by eating, drinking, or smoking in a nonhazardous area before thorough washing of hands and face. Do not eat, drink, or smoke in the blast area. Thoroughly wash hands and face to remove contaminants before eating, drinking, or smoking outside the blast area.

This manual does not contain all the health and safety requirements regarding toxic and hazardous dust exposure. Obtain copies of the OSHA regulations and consult a safety professional and/or industrial hygienist for complete requirements.

Within this manual we refer to hazardous or contaminated environments. These environments can be any places around the blast area that can contain toxic or hazardous dust.

If these warnings are not completely understood, or if further information is required, contact a local OSHA office. If any personnel in the abrasive blasting vicinity cannot read or comprehend these warnings and the entire content of this instructional material, assign a qualified person to instruct him/her.

Additional information on abrasive blasting hazards titled "Preventing Silicosis and Death From Sandblasting", Publication No. 92-102, is available from:

Publications Dissemination, DSDTT
National Institute for Occupational Safety and Health
4676 Columbia Parkway
Cincinnati, OH 45226 (513) 533-8287

1.7 Cautions and Limitations

A - Not for use in atmospheres containing less than 19.5 percent oxygen.

B - Not for use in atmospheres immediately dangerous to life or health (IDLH).

C - Do not exceed maximum use concentrations established by regulatory standards.

D - Air-line respirators can be used only when the respirators are supplied with respirable air meeting the requirements of CGA G-7.1 for Grade D or higher quality.

E - Use only the pressure ranges and hose lengths specified in the user's instructions.

J - Failure to properly use and maintain this product could result in injury or death.

M - All approved respirators shall be selected, fitted, used, and maintained in accordance with OSHA and other applicable regulations.

N - Never substitute, modify, add, or omit parts. Use only exact replacement parts in the configuration as specified by the manufacturer.

O - Refer to user's instructions and/or maintenance manuals for information on use and maintenance of these respirators.

S - Special or critical user's instructions and/or specific use limitations apply. Refer to instruction manual before donning.

1.8 S – Special or Critical User’s Instructions

1.8.1 Air pressure at the point of attachment (the point of attachment is where the respirator supply hose is connected to the respirable air source) must be maintained at pressures between the minimum and maximum pressure, as shown in the table in Section 4.2.

WARNING

Failure to maintain the minimum pressure at the point of attachment may reduce air flow below the minimum flow required by OSHA. Reduced air flow may result in ingress of hazardous toxic dust, subjecting the user to immediate health and life threatening poisoning and subsequent respiratory disease.

1.8.2 Couple no more than the maximum number of sections and total maximum lengths of respirator air-supply hose, as noted in the table in Section 4.2.

1.8.3 The respirator is designed for specific use in abrasive blasting applications. Do not use in other operations such as painting or welding.

1.9 Protection Factors

1.9.1 NIOSH-recognized Assigned Protection Factor (APF) for the Apollo Type CE respirator is 25 times the permissible exposure limit (PEL). In other words, NIOSH recommends the Apollo Type CE respirators should only be used in atmospheres in which the contaminant level does not exceed 25 times the PEL. However, OSHA’s 2006 revised Respirator Standard allows an exception for Type CE respirators that have validated third-party testing for use up to 1000 APF. In order not to be in violation of OSHA 1000 APF, the end user must have a copy of this validated testing. A copy of Clemco validated testing may be downloaded from the "Safety Info" tab on our website: www.clemcoindustries.com.

1.9.2 Head: The respirator protects the wearer’s head and neck from impact and from abrasion caused by rebounding abrasive.

- Apollo Model 600 Respirator meets physical requirements for industrial head protection as stated in ANSI Z89.1, as a Type I, Class G protective helmet.
- Apollo Model 20 Respirator does not meet the requirements for industrial head protection as stated in ANSI Z89.1.

1.9.3 Face and Eye: Apollo inner lenses meet impact and penetration requirements under ANSI Z87.1.

1.9.4 Hearing: Noise generated by Apollo Respirators and measured inside the helmet does not exceed 80 decibels. (42 CFR part 84.140) When any exterior noise causes the internal noise level to exceed 80 decibels, the user must wear additional hearing protection. A variety of hearing protectors can be worn with the respirator.

2.0 INSPECTION

NOTE: Clemco respirator air-supply hose(s) are part of the approval assembly and must be used with the respirator. Some respirators are ordered without a hose because blast operators are often assigned personal respirators, with which they use common respirator hoses. If a Clemco respirator hose is not available, it must be ordered from an authorized distributor of Clemco products.

2.1 Component Checklist – Refer to Figure 1

2.1.1 Make sure that all the respirator components are present. Each respirator box should contain the following:

- One of the following helmet assemblies
 - Apollo 20:** With chin strap, DLX padded suspension, and cape attached, and a loose web suspension.
 - Apollo 600:** With chin strap, DLX padded suspension or web suspension, and cape attached.
- Breathing tube assembly.
- Constant-flow connector with belt

NOTE: If the respirator does not include an approved Clemco respirator hose, and if one is not at the work site for use with the respirator, one or more of the following alternate hoses must be ordered separately:

- 1/2" ID x 50 ft. respirator hose22510
- 1/2" ID x 100 ft. respirator hose21413

2.1.2 When all of these components are present, prepare the respirator for operation per Section 3.0.

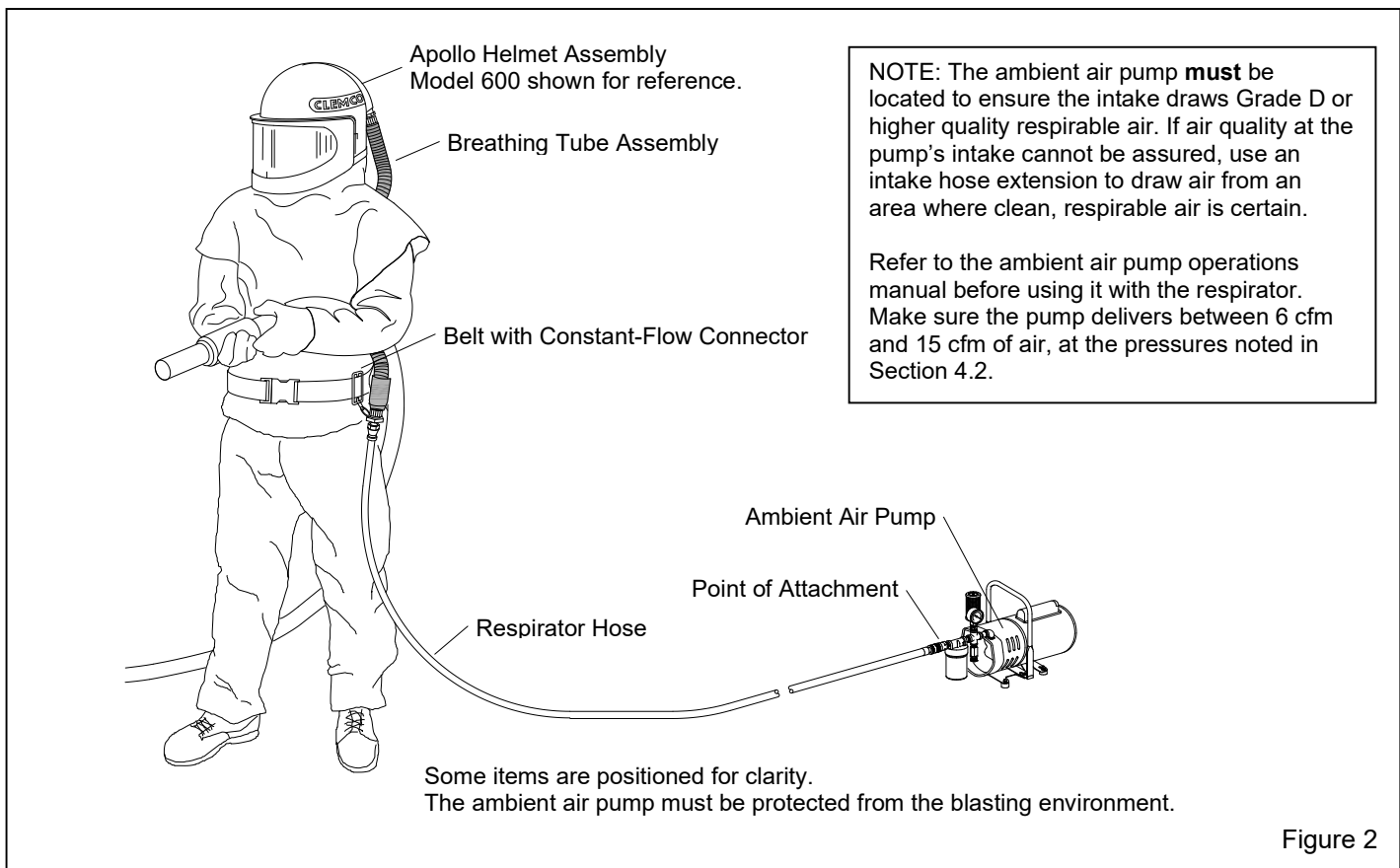
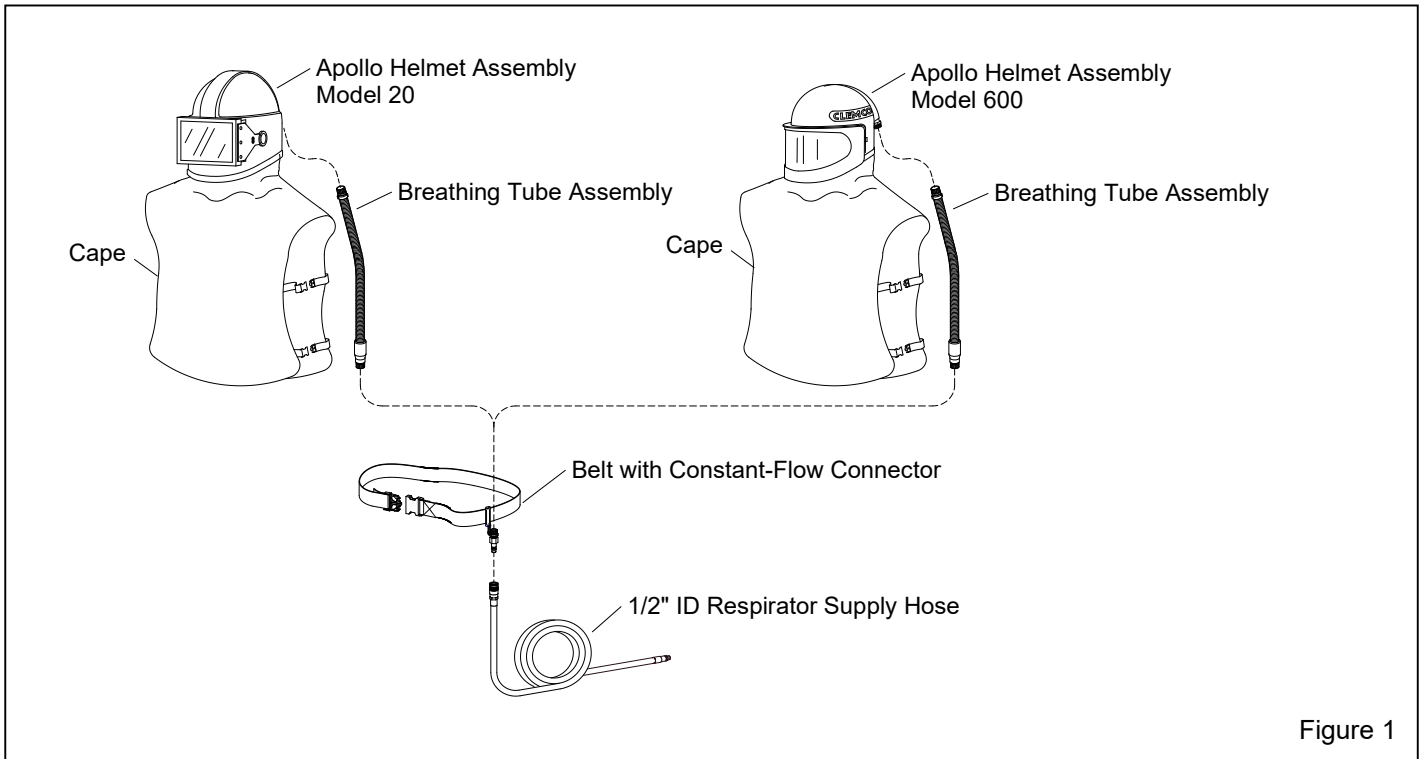

3.0 PREPARATION

Refer to Figure 2 for a typical system setup.

3.1 Adjust Web Suspension

- Apollo 20: Refer to Section 6.1.1 to adjust web suspension.
- Apollo 600: Refer to Section 6.1.2 to adjust web suspension.

3.2 Prepare Lens System

3.2.1 The lens system is an important part of the respirator assembly. The helmet is supplied with an inner lens that is secured by the window gasket. To protect the inner lens, a middle lens and up to three perforated cover lenses are securely held in position by the lens gasket and frame.

3.2.2 Make sure inner lens is in place; refer to the section noted below:

*Apollo 20 – Refer to Refer to Section 9.3.
Apollo 600 – Refer to Refer to Section 10.2.*

3.2.3 When the perforated cover lenses are correctly installed, as one lens becomes frosted during blasting, it can be torn off to expose the next lens. To protect the inner lens, make sure the perforated cover lenses and middle lens are in place, per section noted above.

3.3 Attach Breathing Tube Assembly

CAUTION

Note the directional flow arrows on the labels at both ends of the breathing tube. The flow arrows indicate the direction of air flow to the helmet. Flow arrows must point toward the helmet. Failure to properly attach the breathing tube may damage the tube's acoustical foam, which will block air flow, or it may increase noise levels beyond OSHA limits.

3.3.1 The breathing tube has a clamped-on end and a molded-on end. Attach the clamped-on end to the threaded air-inlet fitting at the back of the helmet, as shown in Figure 3. Do not overtighten the connector; hand-tight is sufficient.

3.3.2 Attach the molded-on swivel connector to the constant-flow connector.

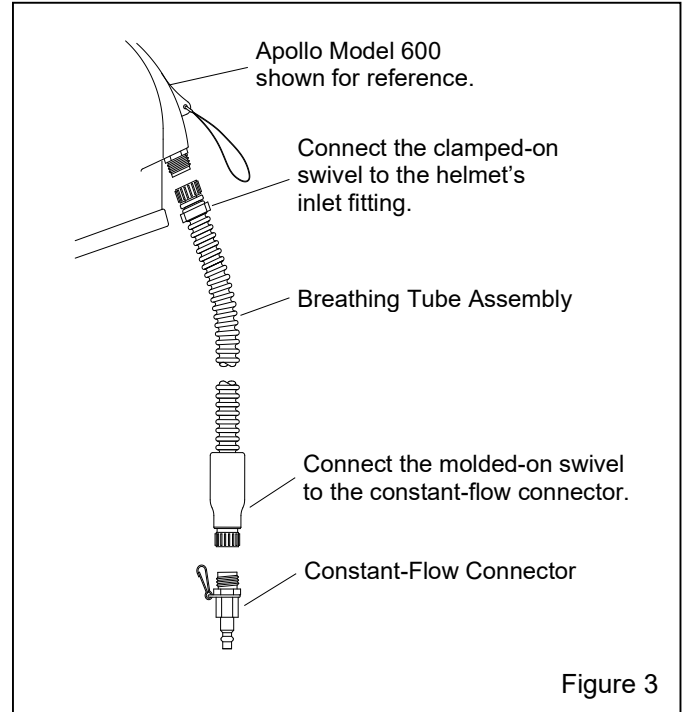

Figure 3

CAUTION

Use the handle to carry or hang the respirator. Never hold, carry, or hang the respirator by the breathing tube. Mishandling the respirator in this manner may damage the tube or helmet inlet. Any leaks or breaks in the breathing tube will alter the air flow through the respirator and affect user's safety and comfort.

3.4 Prepare Respirator Air-Supply Hose

WARNING

OSHA regulations 29 CFR 1910 and 29 CFR 1926 require that respirator air-line couplers be incompatible with air lines for nonrespirable use. This incompatibility prevents inadvertent supply of respirators with potentially hazardous, nonrespirable gases or oxygen. It is the employer's or facility owner's responsibility to comply with the regulation.

3.4.1 Respirator hose must be NIOSH-approved Clemco 1/2" ID respirator hose.

3.4.2 If longer hose is required, it must be a NIOSH-approved Clemco 1/2" respirator hose extension. Use 50-foot or 100-foot Clemco respirator hoses in any

combination as noted in the table in Section 4.2, not to exceed 300 ft. or three individual hose lengths.

3.4.3 Attach the female disconnect end of the respirator hose to the constant-flow connector. The male end attaches to the ambient air pump.

4.0 AIR SUPPLY

WARNING

Air supplied to this respirator system is critical to the safety of the user. Read this section carefully. Poor quality air or low air volume will cause serious respiratory injury or death to the user. See Toxic Dust Poisoning Warning in Section 1.6.

WARNING

This respirator is intended for use with (low-pressure) ambient air pumps. Do not use compressors or high-pressure cylinders (bottles) as an air source for this respirator. Air supplied from compressors poses hazards, especially from carbon monoxide that are not covered in these instructions. High-pressure cylinders require special knowledge for their use and compliance, details of which are not covered in these instructions.

4.1 Air Quality

4.1.1 The quality of air supplied to the respirator is extremely critical to the safety of the user. Special care must also be taken to avoid accidental connection to any other gas lines such as, oxygen, acetylene, or nitrogen.

DANGER

Never connect a breathing-air line to an air source that has not been tested for gas and particulate contamination. The presence of unacceptable levels of carbon monoxide (CO) or other gases, or oxygen deficiency in breathing air will cause death to the user.

4.1.2 The employer is responsible for ensuring that breathing air meets the requirements for Grade D or higher quality, as described in Compressed Gas Association Commodity Specification pamphlet G-7.1., titled Commodity Specification For Air, published by Compressed Gas Association Inc., Chantilly, VA. Website: www.cganet.com (29 CFR 1910.134 (i)).

4.1.3 Limiting characteristics of Grade D air at the time of publication of this manual are as follows:

Carbon Dioxide	maximum of 1000 ppm
Carbon Monoxide	maximum of 10 ppm
Odor	*No pronounced odor
Oil (hydrocarbons)	maximum of 5 mg/m ³
Oxygen	between 19.5 - 23.5%

* Specific measurement of odor in gaseous air is impractical. Air may have a slight odor but the presence of a pronounced odor renders the air unsatisfactory.

4.1.4 Prior to using the respirator, read the owner's manual and all instructions, labels, and warnings relating to the ambient air pump.

WARNING

The air pump must be located where Grade D or higher quality respirable air is ensured. If air quality at the pump's intake cannot be assured, use an intake hose extension to draw air from an area where clean, respirable air is certain. Any toxic air entering the pump will enter the respirator and will cause severe illness or death to the user.

4.1.5 Take precautions to prevent contaminants from entering through the air pump's inlet filter. Locate the air pump's inlet filter away from all sources of contaminants including carbon monoxide, which is found in engine exhaust, and in any form of combustion. Place the pump in an area away from vehicle traffic. Do not locate the pump's inlet filter near any exhaust system outlet, ventilation flue, or source of fumes or particles of any kind. If the ambient air pump cannot be placed in an area where respirable air can be guaranteed, use an air-inlet extension hose as specified by the pump manufacturer to bring air from an area where clean respirable air is ensured.

S – Special or Critical User’s Instructions

4.2 Air Volume and Pressure Requirements

4.2.1 LP respirators are for use with ambient pumps, which provide 6 to 15 cfm of Grade D air at pressures shown in the table in this section. Maintaining the correct operating pressure at the point of attachment ensures the correct air flow to the respirator.

4.2.2 Use the following table to determine the minimum and maximum pressure settings and maximum respirator hose length. Adjust the pressure with the respirator hose and respirator attached. If the regulator is adjusted with static pressure (no air flow), pressure may drop below the required pressure when the respirator is connected, and may result in low air flow. Setting the pressure as instructed will provide a minimum of 6 cfm to the respirator.

Total Hose Length	Maximum Number of Hose Sections	Pressure (psi)	
		Min.	Max.
50 feet	1	8	12
100 feet	2	9	17
200 feet	2	12	20
300 feet	3	15	20

NOTE: Use any combination of hose shown to provide a maximum of 300 ft., but not to exceed three individual hose lengths.

4.3 Pressure Conversion Kit

4.3.1 This optional accessory kit contains parts and instructions to convert an Apollo respirator from low pressure (for use with an ambient air pump) to high pressure (Grade “D” Compressed Air). The kits are listed in the section noted below:

- Apollo 20 – Accessories Section 11.2.1.*
- Apollo 600 – Accessories Section 11.2.2.*

5.0 OPERATION

 WARNING

Except for emergency evacuation when the use of the respirator hinders escape, keep the respirator on and leave the respirator-use area immediately if any of the following occur:

- **Any part of the respirator system becomes damaged**
- **Any air monitoring alarm is activated**
- **Air flow into the respirator is reduced or stops**
- **Breathing becomes difficult**
- **At the first sign of dizziness, nausea, fever, illness, or injury**
- **Any contamination is noted by taste, smell, or vision inside the respirator**
- **Vision becomes impaired**
- **Any irritation is noted**

5.1 Inspection and Preparation

5.1.1 Prior to use, thoroughly inspect and clean the helmet, breathing tube, respirator hose, air entry ports, and fittings of all dust and debris. Inspect the helmet suspension and if necessary adjust it, per Section 6.1, or replace it per the section noted below:

- Apollo 20 – Refer to Section 9.7.*
- Apollo 600 – Refer to Section 10.6.*

5.1.2 Connect the female disconnect on respirator hose to the constant flow connector. Tug on the hose to make sure the connection is secure.

5.1.3 Connect the male disconnect of the respirator hose to the ambient air pump. Tug on the hose to make sure the connection is secure.

5.1.4 Begin the operation of the ambient air pump per the manufacturer’s instructions.

5.1.5 Check air pressure at the air pump (the point of attachment). Pressure must be within the minimum and maximum pressures assigned in Section 4.2. Pressure must be set with the respirator connected.

5.1.6 Inspect all safety and breathing equipment used in conjunction with the respirator, as recommended by the manufacturer.

5.2 Donning (putting on) the Respirator

5.2.1 Inspect respirator hoses and connections for tightness and leaks. If a leak is found at a disconnect coupling, replace both the disconnect plug and socket.

5.2.2 Don the respirator in a clean nonhazardous environment, free of contaminants, where the air is safe to breathe.

NOTE: If convenient to do so, the respirator hose may be left attached to the respirator while donning the respirator. If it is not convenient to do so, attach the respirator hose as soon as practical after donning the respirator.

5.2.3 When donning and doffing the respirator, keep it upright to prevent dust and abrasive from falling inside. Holding the chin strap while donning the helmet will make it easier to position it once the helmet is on.

5.2.4 Position the chin strap so it fits comfortably under the chin.

5.2.5 Position the knit cuff on the inner collar so that it fits snugly around the neck in turtleneck fashion and without any interference from clothing or long hair. When correctly positioned, the smaller elastic end of the collar must face up.

WARNING

Correct placement of the inner collar is critical for providing the protection for which the respirator is designed. Failure to position and maintain the inner collar around the user's neck — without any interference from items such as hair, facial hair, or shirt collars — can result in in abrasive and dust ingress into the helmet.

5.2.6 Pull the cape down to fully extend it, and connect the four elastic straps (two on each side) under the arms, and tighten using the slides provided.

5.2.7 Put on the belt and control valve over the cape. Buckle the belt around the waist and tighten it by pulling the belt end through the buckle insert.

5.3 Doffing (taking off) the Respirator

5.3.1 When finished blasting, and after cleanup is completed, remove the respirator outside the respirator-use area and where the air is safe to breathe.

WARNING

Do not don, doff, or store the respirator in a blast-contaminated environment. Do not remove the respirator in a contaminated environment except for during emergency evacuation, when the use of the respirator hinders escape.

5.3.2 Unfasten the cape straps and belt buckle.

5.3.3 Working from under the inner collar, remove the chin strap from under the chin and lift the respirator straight up to prevent abrasive and dust from falling inside.

5.3.4 Before removing the respirator hose from the constant-flow connector, make sure the air supply is OFF and air is bled from the respirator hose. Cover both connectors (on the constant-flow connector and respirator hose) to avoid damage and to prevent contaminant from entering the connectors.

NOTE: The quick disconnect socket on the end of the respirator hose is not equipped with a shut-off. Therefore, if the hose is disconnected from the respirator while the pump is in operation, air will continue to freely-flow from the hose. After removing the respirator in a clean environment, the air pump should be shut off.

6.0 ADJUSTMENTS

6.1 Web Suspensions

WARNING

The suspension maintains a fixed distance between the head and the helmet. It is critical that the suspension is properly installed, and adjusted as described, to provide maximum head protection and comfort.

6.1.1 Apollo 20 alternate web suspension with sweatband – Figure 4

Refer to Section 6.1.2 to adjust Apollo 600 web suspension.

The Apollo 20 helmet includes both the web suspension and DLX padded suspension; try both and use the one the operator prefers.

6.1.1.1 Remove cape from the helmet per Section 9.6.

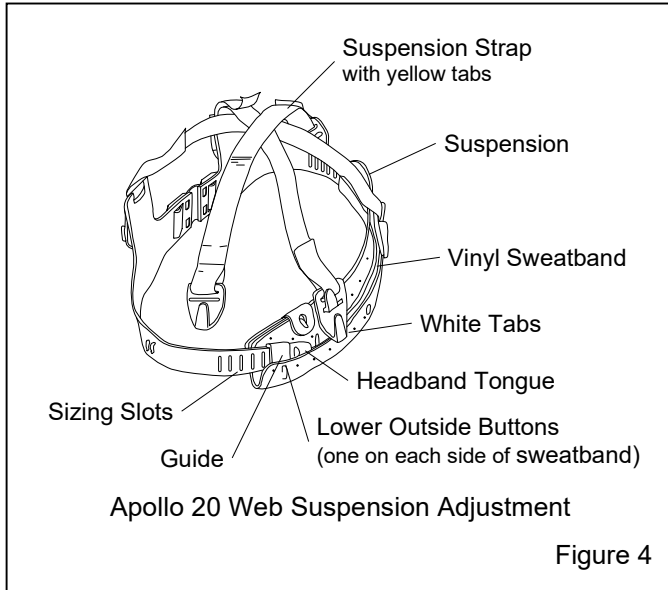

6.1.1.2 Unfasten the vinyl sweatband from the two lower, outside buttons; refer to Figure 4. It is not necessary to remove the suspension to make adjustments.

6.1.1.3 The suspension fits head sizes 6.5 to 8. Head sizes are marked on the headband slots. Slide the headband tongue in or out of the guide to attain the desired head size. It is important that the adjustment be made evenly on both sides. Press the selected slots firmly onto the fastening lugs on the front band.

6.1.1.4 Refasten the vinyl sweatband onto the suspension buttons.

6.1.1.5 Try on the helmet for fit and readjust if necessary.

6.1.1.6 Reattach the cape to the helmet by following the instructions in Section 9.6.

6.1.2 Apollo 600 alternate web suspension with sweatband – Figure 5

Refer to Section 6.1.1 to adjust Apollo 20 web suspension.

6.1.2.1 Remove the cape from the helmet per Section 10.8. NOTE: After the initial adjustment, minor adjustments may be made without removing the cape.

6.1.2.2 Try on the helmet for fit and adjust the suspension by turning the adjustment knob clockwise to decrease the size, or counterclockwise to increase the size. The suspension fits head sizes 6.5 to 8.

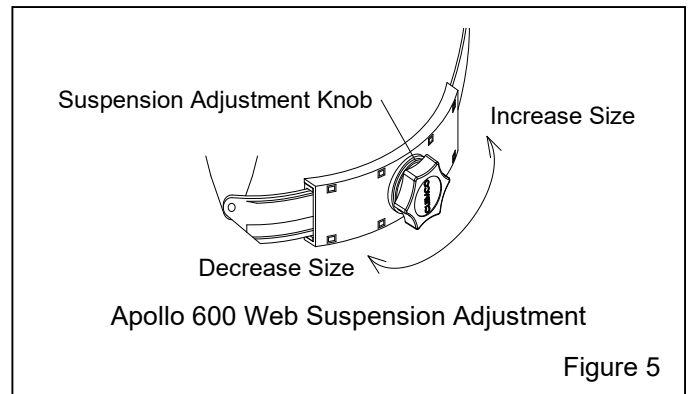

6.1.2.3 Reattach the cape to the helmet by following the instructions in Section 10.8.

6.2 DLX Padded Suspensions

⚠ WARNING

The suspension maintains a fixed distance between the head and the helmet. It is critical that the suspension is properly installed, and adjusted as described, to provide maximum head protection and comfort.

6.2.1 Apollo 20 alternate DLX padded suspension

Refer to Section 6.2.2 to adjust Apollo 600 DLX padded suspension.

The Apollo 20 helmet includes both the web suspension and DLX padded suspension; try both and use the one the operator prefers.

6.2.1.1 There is no adjustment with the DLX padded suspension.

6.2.2 Apollo 600 alternate DLX padded suspension (side pads)

Refer to Section 6.2.1 for the Apollo 20 DLX padded suspension.

6.2.2.1 The helmet comes with two side pads of different thickness. The standard black-grey pad is installed in the helmet; the black-blue pad is loose.

Black-grey (standard) side pad: This pad fits most head sizes.

Black-blue side pad: This pad fits smaller head sizes.

6.2.2.2 Try on the helmet for fit. If the helmet fits too loosely, replace the standard pad with the thicker black-blue pad. NOTE: The grey and blue sides are Velcro® receptive and are placed against the helmet shell. The black side is facing the inside of the helmet.

6.2.2.3 Reattach the cape to the helmet by following the instructions in Section 10.8.

7.0 MAINTENANCE PROGRAM

7.1 Basic Service

7.1.1 A program for maintenance and care of the respirator must be established based on application, working conditions, and hazards involved. The program must include the following basic services:

- Inspection for defects (including a leak check)
- Cleaning and disinfecting
- Repair (service maintenance)
- Storage

Equipment must be properly maintained to retain its original effectiveness. Reference OSHA Regulation 29 CFR 1910.134 (h).

7.2 Inspection

Inspection must be done in compliance with OSHA Regulation 29 CFR 1910.134 (h)(3).

7.2.1 Inspect respirator before and after each use, and during cleaning. Inspection shall include a check for tightness of connections and the condition of the lenses, suspension, cape and elastic parts, breathing tube, respirator hoses, and constant-flow connector.

7.2.2 Inspect the respirator hoses, breathing tube, air entry ports, and fittings for dust contamination; make sure they are clean before making connections.

7.2.3 The helmet suspension is crucial for maintaining maximum head and respiratory protection. It must be inspected for fit and wear on a daily basis, and replaced immediately at the first sign of wear. Refer to the section noted below:

Apollo 20 suspension – Refer to Section 9.7.

Apollo 600 suspension – Refer to Section 10.6.

7.2.4 The inner collar is important for controlling air escape from the helmet and preventing ingress of dust. The elastic collar should fit snugly around the user's

neck. Replace the collar (Apollo 600 collar is replaceable) or cape when the collar no longer fits snugly around the neck.

7.2.5 The cape provides protection from rebounding abrasive and from abrasive ingress into the helmet. Inspect the cape frequently for wear. Replace the cape before holes appear, or any wear occurs that prevents the cape from providing the protection for which it is intended.

7.3 Cleaning and Disinfecting

NOTE: Disinfecting the helmet shell can be done with a solution of no more than 1/4 cup (2 oz) of bleach to 1 gallon of water or with commercial disinfecting wipes. All soft components, such as capes and suspensions, must be washed in warm water with mild detergent. Cleaning and disinfecting must be done in compliance with OSHA Regulation 29 CFR 1910.134 (h)(1). Refer to Section 8.0 for cleaning instructions.

7.3.1 A respirator issued for the exclusive use of an employee shall be cleaned and disinfected as often as necessary to be maintained in a sanitary condition.

7.3.2 Shared respirators must be cleaned and disinfected before being worn by different individuals.

7.3.3 Additional disinfecting may be done before or after use by wiping the surfaces with a commercial disinfecting wipe or spray.

7.4 Repairs (service maintenance)

Repairs must be done in compliance with OSHA Regulation 29 CFR 1910.134 (h)(4).

7.4.1 The employer shall ensure that, respirators that fail an inspection or are otherwise found to be defective are removed from service, adjusted, repaired, or discarded in accordance with the following procedures:

7.4.2 Adjustments and repairs must be made only by appropriately trained persons, and only with genuine Clemco NIOSH-approved parts designed for the respirator. No attempt shall be made to substitute components or to make adjustments or repairs beyond the manufacturer's recommendations. Refer to the sections noted below for service instructions:

Apollo 20 – Refer to Section 9.0.

Apollo 600 – Refer to Section 10.0.

7.5 Storage

Storage of the respirator must be done in compliance with OSHA Regulation 29 CFR 1910.134 (h)(2).

7.5.1 Daily storage

7.5.1.1 When the respirator is not in use, it must be stored in a clean, dry area. Hang the respirator by the handle. Do not tuck the cape inside the helmet. Let the cape hang loose to allow air to circulate and to allow condensation on the cape and inside the helmet to dry.

7.5.2 Long-term storage

7.5.2.1 After inspection, cleaning, and thorough drying, and after necessary repairs are made, the cape should be tucked inside the helmet. The respirator shall be placed in a plastic bag and the bag sealed to keep out dust and moisture. Place the bag in a clearly marked carton and store it in a clean, dry place.

8.0 CLEANING AND DISINFECTING

NOTE: Unless otherwise stated all cleaning and disinfecting should be done in accordance to OSHA Regulation 29 CFR-134 App. B-2.

CAUTION

Follow washing instructions as described in this section. Do not use any caustic chemicals or solvents that may be irritating or harmful to the user, or which change the properties of the materials used in any part of the respirator.

8.1 Cape

8.1.1 Refer to the section noted below for removing and replacing the cape:

Apollo 20 – Refer to Section 9.6.
Apollo 600 – Refer to Section 10.8.

8.1.2 Machine wash in warm water with mild detergent. Dry in a clothes dryer at the lowest temperature setting. Do not dry clean.

8.2 Inner Collar (Apollo 600 only)

8.2.1 The removable inner collar should be frequently washed to remove buildup of dirt that accumulates from normal perspiration and air moisture. For general hygiene, daily washing is recommended.

8.2.2 The inner collar may be either washed or replaced separately or with the cape. To wash separately, unzip the collar and machine wash in warm water with mild detergent. Tumble dry in a clothes dryer at the lowest temperature setting. Do not dry clean.

8.3 Suspensions

8.3.1 DLX padded suspension and chin strap

8.3.1.1 Refer to the sections noted below for removing and replacing the DLX padded suspension and chin strap:

Apollo 20 – Refer to Sections 9.7.1 and 9.8
Apollo 600 – Refer to Sections 10.6.2 and 10.7

8.3.1.2 Wash the suspension pads, suspension web, and chin strap with warm water and mild detergent. Rinse with clean, warm water.

8.3.1.3 Squeeze pads to remove excess water. Wrap pads in a towel and squeeze to remove additional water. All items may be air-dried or tumble-dried at the lowest possible setting.

8.3.2 Web suspension with sweatband and chin strap

8.3.2.1 Refer to the section noted below for removing and replacing the web suspension with sweatband and chin strap:

Apollo 20 – Refer to Sections 9.7.2 and 9.8.
Apollo 600 – Refer to Sections 10.6.1 and 10.7.

8.3.2.2 Wash the sweatband, suspension, and chin strap in warm water and mild detergent. Rinse with clean water. Remove excess water with a towel and allow to air dry.

8.4 Helmet Shell

8.4.1 Clean the helmet shell with a cloth, dampened with water and mild detergent. If the helmet must be immersed in water, remove the breathing tube, cape, suspension and all other removable items before immersing. While this will not permanently damage the helmet, it will require an extended drying period.

8.4.2 Care must be taken to prevent abrasive entry when donning (putting on) and doffing (removing) the respirator and when changing lenses. Vacuum the inside of the helmet to remove any abrasive.

8.5 Disinfecting

8.5.1 Washing the respirator as instructed also disinfects it. Additional disinfecting may be done before and/or after use by wiping the surfaces with a commercial disinfecting wipe or spray. Disinfecting the helmet shell can be done with a solution of no more than 1/4 cup (2 oz) of bleach to 1 gallon of water.

9.0 SERVICE MAINTENANCE – APOLLO MODEL 20

Refer to Section 10.0 for Apollo Model 600 Service Maintenance

⚠ CAUTION

To prevent recontamination of the respirator, clean the respirator of dust and abrasive before maintenance. All maintenance must be done in a clean environment away from dust and abrasive, and outside the respirator use area.

9.1 Apollo 20 Lens System

⚠ WARNING

Never use the respirator without a complete lens system in place. A complete lens system includes the fixed inner lens, middle lens, perforated cover lenses, and lens gasket. The fixed inner lens provides support for the window gasket. If the gasket is not adequately supported, leaks can occur that can permit entry of toxic and hazardous dust or abrasive into the helmet.

9.2 Replacing Cover and Middle Lenses – Figure 6

NOTE: Preparing lenses in the following manner will permit the cover lenses to be torn off while blasting to expose a fresh lens as needed, while preserving the innermost perforated lens to protect the middle lens.

9.2.1 Unlatch and open the lens frame, and remove remnants of old lenses. The middle lens may be reused if it is in good condition.

9.2.2 Inspect the lens frame gasket; replace if worn or damaged.

9.2.3 Inspect the inner lens and window gasket. Replace the inner lens when it becomes badly scratched or damaged and replace the gasket if it is damaged. Refer to Section 9.3.

9.2.4 Up to three cover lenses may be installed at one time. For maximum visibility, install only enough lenses to last during a work period.

9.2.5 Preparing lenses in the following manner will permit lenses to be pulled off easily by a user wearing heavy gloves.

9.2.6 Place the middle lens on a clean flat surface. Place up to three cover lenses on top of it.

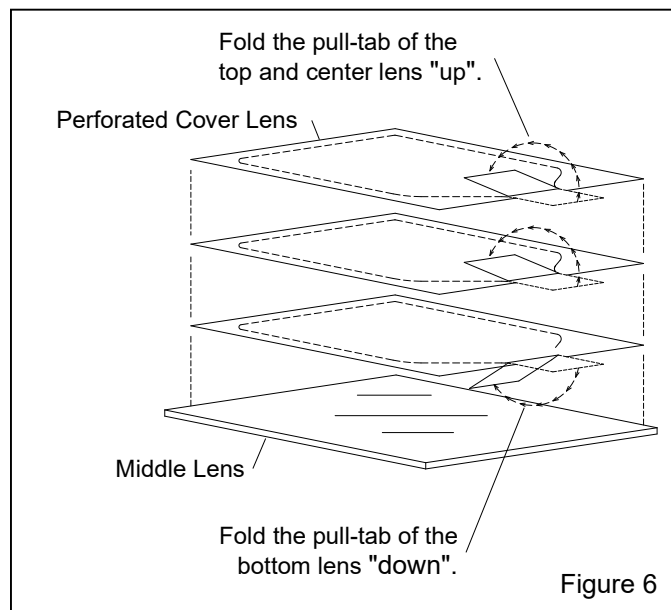

9.2.7 Fold the pull-tab of the bottom lens down, as shown in Figure 6.

9.2.8 Fold the pull-tab of the center and top lens up.

9.2.9 Place the stack of prepared lenses into the lens frame so the pull-tab of the top lens sticks through the front of the lens opening. When placed correctly, the perforated lenses will be against the frame, and the middle lens will be behind them offering additional support.

9.2.10 Installing the lenses in this manner will prevent unintentional removal of the last perforated lens and prolong the life of the middle and inner lenses. It will be easier to remove the cover lens while wearing heavy gloves if the tab is bent outward slightly.

9.3 Remove and Replace the Inner Lens and Window Gasket – Figure 7

9.3.1 Open the lens frame, and remove the middle lens and cover lenses.

9.3.2 Pull the lens gasket and inner lens off the window-opening flange. The gasket is held in place by tabs on the flange that fit into slots on the gaskets, as shown in Figure 7.

9.3.3 Remove old lens from the gasket lens channel.

9.3.4 Clean or replace the gasket as needed.

9.3.5 Place a new lens into the channel. The lens must be in place before affixing the gasket to the window flange.

9.3.6 Slide one end of the gasket (with lens) onto the window-opening flange so the holding tab on the opening is inserted into the gasket retaining-slot.

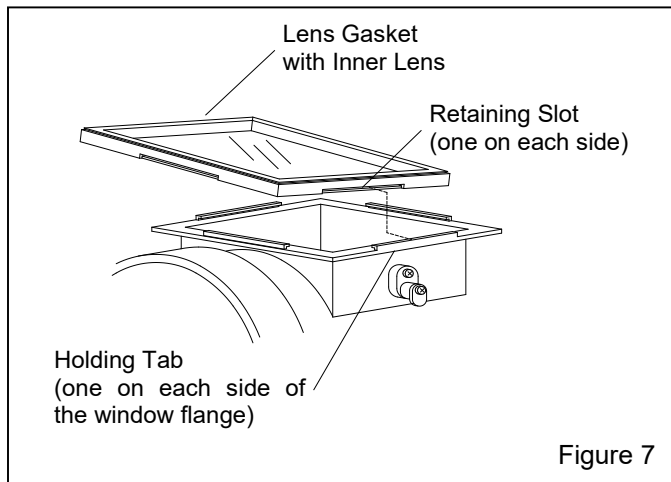

Figure 7

9.3.7 Push the gasket against the flange. Working from inside the helmet, push the gasket toward the tab until the tab is fully inserted into the retaining slot.

9.3.8 Repeat the process on the opposite side. The gasket must be pushed beyond the holding tab in order to insert it into the slot.

9.3.9 Repeat the process on the top and bottom to lock the gasket in place.

9.3.10 Place perforated cover lenses and one middle lens in the lens frame, per Section 9.2, before closing the frame.

9.3.11 To maximize the wear life of the inner and middle lenses, do not remove the last perforated cover

lens (refer to Sections 9.1 and 9.2). The respirator must never be used without the inner and middle lenses in place.

9.4 Remove and Replace the Lens Frame

9.4.1 The lens frame must be replaced at the first sign of wear or of cracking around the hinge.

9.4.2 Open the lens frame and remove the perforated cover lenses and middle lens.

9.4.3 Remove the two hinge screws and replace the frame.

9.4.4 Install a new frame gasket before installing new lenses.

9.5 Remove and Replace Rubber Window-Frame Latch

9.5.1 Pull the old latch off the three buttons.

9.5.2 Place the flat side of the latch against the frame and align the holes in the new latch over the buttons.

9.5.3 Push the latch over each button, making sure the rubber is fastened under the button.

9.6 Remove and Replace the Cape – Figure 8

9.6.1 When the cape becomes soiled or needs to be replaced, it can easily be removed as follows:

9.6.2 Separate the Velcro® tabs on the back of the cape. Refer to Figure 8.

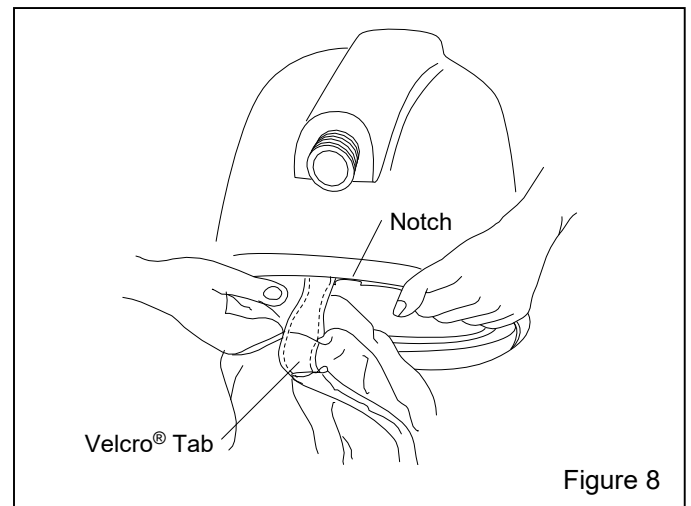

Figure 8

9.6.3 Slide the ends of the cape to the notch. Continue sliding one end of the cape out of the groove until the entire cape is detached from the helmet.

9.6.4 To install the cape, separate the Velcro® tabs on the cape and slide one end into the groove on the bottom edge of the cape attachment strap at the point where the groove is notched. Continue sliding the cape around the bottom of the helmet until the entire cape is completely into the groove. NOTE: Spraying a nontoxic silicone-based lubricant into the groove will reduce friction and ease assembly.

9.6.5 Join the Velcro® tabs at the notch.

9.7 Remove and Replace Suspensions

9.7.1 DLX padded suspension, standard

9.7.1.1 All pads are held in place with Velcro® hook and loop strips. The green side of the pad is Velcro® receptive, the black side is not. Remove the side and middle pads by pulling them free of the hook strips.

9.7.1.2 Remove the suspension web by extracting the plastic tabs from the mounting slots in the helmet shell. While holding the top pad in place, pull the webbing to separate it from the top pad.

9.7.1.3 To remove the top pad, hold the air-channel partition (Figure 16 – Item 13) in place and pull the pad to separate it from the partition.

9.7.1.4 Inspect the chin strap, and if necessary replace it, per Section 9.8 before installing the suspension.

9.7.1.5 Make sure the air-channel partition is correctly positioned, per Section 9.9, before installing the top pad. Align the pad while pressing it into place against the fastener strip.

9.7.1.6 Place the suspension web under the chin strap and then secure the suspension by inserting the plastic tabs into their respective mounts; the yellow tabs go into the side mounts.

9.7.1.7 Align the middle pad so the elastic cord is toward the back and the center of the pad is centered to the suspension web. Press the pad to engage the Velcro® strip; minor repositioning may be needed to fully seat the pad.

9.7.1.8 The Velcro® receptive green side of the side pad faces toward the helmet shell and is attached by

pressing it onto the Velcro® hook strips. The black side faces toward the inside of the helmet.

9.7.1.9 Reattach the cape to the helmet by following the instructions in Section 9.6.

9.7.2 Web suspension with sweatband, alternate

9.7.2.1 Remove cape from the helmet, per Section 9.6.

9.7.2.2 Remove and discard the old suspension and suspension strap by extracting the plastic tabs from the wedge-shaped clefts in the shell.

9.7.2.3 Unfasten the vinyl sweatband from the two lower, outside buttons; refer to Figure 4.

9.7.2.4 The suspension fits head sizes 6.5 to 8. Head sizes are marked on the headband slots. Slide the headband tongue in or out of the guide to attain the desired head size. It is important that the adjustment be made evenly on both sides. Press the selected slots firmly onto the fastening lugs on the front band.

9.7.2.5 Refasten the vinyl sweatband onto the suspension buttons.

9.7.2.6 Install the suspension strap before installing the suspension. Insert the yellow end tabs into the clefts on the helmet shell. When correctly installed, the strap is between the suspension and helmet shell and above the ears.

9.7.2.7 Install the suspension by inserting the four white plastic tabs into the clefts on the shell. The tabs must fully seat in their respective clefts.

9.7.2.8 Try on the helmet for fit and readjust if necessary. It is not necessary to remove the suspension to make adjustments.

9.7.2.9 Make sure the chin strap is in place, then reattach the cape to the helmet by following the instructions in Section 9.6.

9.8 Remove and Replace the Chin Strap

9.8.1 Replace the chin strap when worn, it loses its elasticity, or falls off the holders.

9.8.2 Remove the cape, per Section 9.6.

9.8.3 DLX Padded Suspension only: Pull back the forward ends of the padding to uncover the chin strap clips.

9.8.4 Push UP on the chin-strap clip to remove it from the holder, as shown in Figure 9.

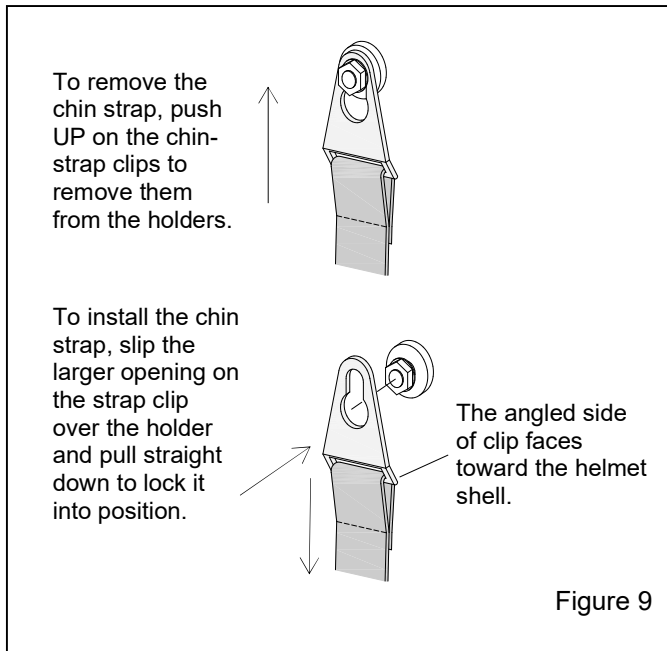

9.8.5 To install the chin strap, position it so the angle on the clips point toward the helmet shell, slip the larger opening on the clip over the holders, as shown in Figure 9, and pull straight down to lock the clips into position.

9.8.6 Place the chin strap over the top of the DLX side pad and attach the side pad by pressing the ends onto the Velcro® hook strips.

9.8.7 Reattach the cape to the helmet by following the instructions in Section 9.6.

9.9 Remove and Replace the Air-Channel Partition. Figure – 10

9.9.1 Remove the breathing tube, cape (per Section 9.6), and suspension (per Section 9.7).

9.9.2 Pull the partition from the front to unsnap it from the retainers. Remove the backend of the partition from the tabs at the back of the helmet shell.

9.9.3 If using padded suspension, place the new partition next to the old one and apply a piece of Velcro® hook tape at the same location as the old one.

9.9.4 Place a new partition into the helmet. Insert the slots on the partition behind the retaining tabs at the back of the helmet shell and push the slots into the tabs to secure.

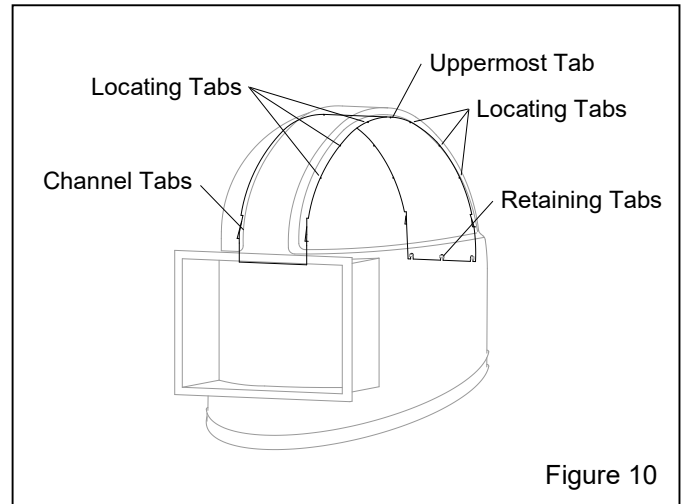

9.9.5 While applying pressure on the front of the partition, align the two notches at the center of the partition with the uppermost tabs on the helmet shell and then press on the partition to snap it into place.

9.9.6 Working from the center, uppermost tabs toward the front and back, snap the partition into place between all locating tabs and the front and back channel tabs. The partition will extend about 3/8" below the top of the window frame.

9.9.7 Reattach the breathing tube, suspension, and cape.

10.0 SERVICE MAINTENANCE – APOLLO MODEL 600

Refer to Section 9.0 for Apollo Model 20 Service Maintenance

CAUTION

To prevent recontamination of the respirator, clean the respirator of dust and abrasive before maintenance. All maintenance must be done in a clean environment away from dust and abrasive, and outside the respirator use area.

10.1 Apollo 600 Lens System

Fixed Inner Lens: Replaceable lens required by OSHA must be used with all lens systems. Refer to Section 10.2 for replacement of fixed inner lens.

Nonperforated Intermediate Lens: Protects the inner lens and supports the perforated outer lens. Refer to Section 10.3.

Perforated Outer Lens: Use in multiples (up to three) over intermediate lens. For high-abrasion applications and/or the convenience of tearing off frosted lenses during the work period. Refer to Section 10.4.

Rectangular Lens: Protects inner lens. Refer to Section 10.5.

WARNING

Never use the respirator without a complete lens system in place. A complete lens system includes the fixed inner lens and one of the lens options noted below. The fixed inner lens provides support for the window gasket. If the gasket is not adequately supported, leaks can occur that can permit entry of toxic and hazardous dust or abrasive into the helmet.

NOTE: Choose one of the following lens system options:

- a. Fixed inner – one intermediate – up to three perforated outer lenses.
- b. Fixed inner – one intermediate – no perforated outer.
- c. Fixed inner – one rectangular – no perforated outer.

10.2 Remove and Replace the Fixed Inner Lens and Window Gasket

NOTE: The following instructions explain the method of first installing the gasket onto the helmet and then the lens. Spraying a small amount of water or food grade silicone into the gasket grooves will reduce friction and ease installation. Alternatively, install the lens into the window gasket and then install the lens and gasket onto the helmet as an assembly. Warming the gasket makes the installation easier.

10.2.1 Replace the inner lens when it becomes dirty or scratched.

10.2.2 Remove the cape to ease the installation.

10.2.3 Unlatch and open the window frame.

10.2.4 Working from inside the helmet, pull up on the window gasket lip and push out the gasket and lens through the front of the window opening.

10.2.5 Remove the old lens from the gasket.

10.2.6 Inspect the window gasket and replace it if damaged.

10.2.7 Place the gasket over the window opening. Align the notch in the gasket with the tab at the bottom of the helmet window opening. Keeping the notch and tab aligned ensures the gasket is centered on the window opening.

10.2.8 From the inside of the helmet, work the gasket lip onto the helmet. Smooth out wrinkles in the gasket on the inside of the helmet.

10.2.9 Insert one end of the lens into the gasket groove. The lens must be fully seated into the groove.

10.2.10 Work the lens into the groove until it is completely seated into the gasket's groove.

10.2.11 Install the intermediate and outer lenses, and latch the window frame.

10.2.12 To maximize the wear life of the inner lens, do not use without an intermediate lens. The respirator must never be used without the inner lens in place.

10.2.13 Attach the cape.

10.3 Intermediate Lens

10.3.1 Unlatch and open the window frame, and remove the old lens.

NOTE: It is not necessary to use perforated outer lenses, but they will protect the intermediate lens when rapid frosting occurs. If outer lenses are used, they must be installed before the intermediate lens, per Section 10.4.

10.3.2 Inspect the window gasket and inner lens. If necessary replace, per Section 10.2.

10.3.3 Align the new lens with the straight edge toward the top and round mounting holes on the hinge end of the frame.

10.3.4 Secure the lens to the frame by pressing the round mounting holes onto the mushroom-shaped locating lugs. The oval holes on the other end of the lens fit onto the lugs on the latch end of the frame.

10.3.5 Close and latch the window frame.

10.4 Perforated Outer Lenses – Figure 11

For maximum visibility, install only enough lenses to last during a work period, but no more than three. Preparing lenses in the following manner will permit the outer lenses to be torn off while blasting to expose a fresh lens as needed, while preserving the innermost perforated lens to protect the intermediate lens.

10.4.1 Stack up to three lenses on a clean, flat surface. Arrange them with the flat edge at the top and the pull-tabs on the left. Fold up the pull-tab on the center lens up, so that the pull-tab is against the top lens.

10.4.2 Unlatch the window frame and remove remnants of old lenses.

10.4.3 Inspect the window gasket and inner lens. If necessary, replace per Section 10.2.

10.4.4 Place the stack of lenses inside of the opened window frame. Align them with the straight edge toward the top of the frame and the **pull-tabs at the hinged end**.

10.4.5 Insert the pull-tab of the outermost lens through the frame opening. The pull-tab of the innermost lens should remain on the inside. Placing the pull-tabs as described will prevent unintentional removal of the last lens and prolong the life of the intermediate lens.

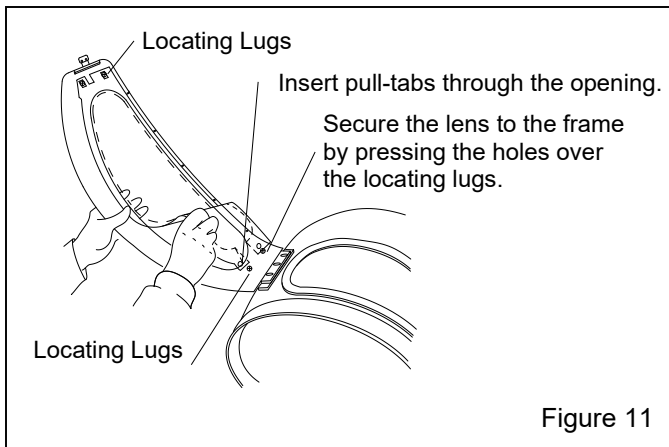

10.4.6 Secure the lenses to the frame by pressing the lens mounting holes on the pull-tab end of the lenses onto the mushroom-shaped locating lugs. The slots on the other end of the lenses fit over the locating lugs on the latch end of the frame.

10.4.7 Using the same locators, install the intermediate lens atop the perforated lenses while the window frame is open.

10.5 Rectangular Cover Lens

10.5.1 Open the window frame and remove the old lens.

10.5.2 Place a new lens between the locating lugs, and then close and latch the window frame to secure.

10.6 Remove and Replace Suspensions

10.6.1 Web suspension with sweatband

10.6.1.1 Remove and discard the old suspension by extracting the plastic suspension tabs from the mounting slots in the helmet shell.

10.6.1.2 Inspect and if necessary replace the chin strap before installing the suspension. When correctly installed, the chin strap is between the suspension and helmet shell.

10.6.1.3 Inspect the metal suspension clips located on the helmet's suspension mounts. Replace them if they are loose or missing.

10.6.1.4 Place the suspension under the chin strap and then secure the suspension by inserting the plastic tabs into their respective mounts. The tabs must fully seat in the mounts.

10.6.1.5 Try on the helmet for fit and adjust the suspension by turning the adjustment knob clockwise to decrease the size, or counterclockwise to increase the size. The suspension fits head sizes 6.5 to 8.

10.6.1.6 Reattach the cape to the helmet by following the instructions in Section 10.8.

10.6.2 DLX padded suspension

10.6.2.1 All pads are held in place with Velcro® hook and loop strips. Remove the side and middle pads by pulling them free of the hook strips.

10.6.2.2 Remove the padded-suspension web by extracting the plastic tabs from their respective mounting slots in the helmet shell. While holding the top pad in place, pull the webbing to separate it from the top pad.

10.6.2.3 To remove the top pad, hold the air channel partition (Figure 17 – Item 12) in place and pull the pad to separate it from the partition.

10.6.2.4 Inspect the chin strap, and if necessary replace it before installing the suspension.

10.6.2.5 Inspect the metal suspension clips located on the helmet's suspension mounts. Replace them if they are loose or missing.

10.6.2.6 Make sure the air-channel partition is correctly positioned, per Section 10.13, before installing the top pad. Align the pad while pressing it into place against the fastener strip.

10.6.2.7 Place the suspension web under the chin strap and then secure the suspension by inserting the plastic tabs into their respective mounts; the tabs with the stripe on the strap go on the side mounts.

10.6.2.8 Align the middle pad so the elastic cord is facing toward the back of the helmet. Press the pad to attach it to the Velcro® hook strips on the air-channel partition; minor repositioning may be needed to fully seat the pad.

10.6.2.9 The Velcro® receptive grey (standard) or blue (for smaller head sizes) side of the side pad faces toward the helmet shell and is attached by pressing it onto the Velcro® hook strips. The black side faces toward the inside of the helmet.

10.6.2.10 Reattach the cape to the helmet by following the instructions in Section 10.8.

10.7 Remove and Replace the Chin Strap

10.7.1 Replace the chin strap when worn, it loses its elasticity, or falls off the holders.

10.7.2 Remove the cape, per Section 10.8.

10.7.3 DLX Padded Suspension only: Pull back the forward ends of the padding to uncover the chin strap clips.

10.7.4 Push UP on the chin-strap clip to remove it from the holder, as shown in Figure 12.

10.7.5 To install the chin strap, position it so the angle on the clips point toward the helmet shell, slip the larger opening on the clip over the holders, as shown in Figure 12, and pull straight down to lock the clips into position.

10.7.6 Place the chin strap over the top of the DLX side pad and attach the side pad by pressing the ends onto the Velcro® hook strips.

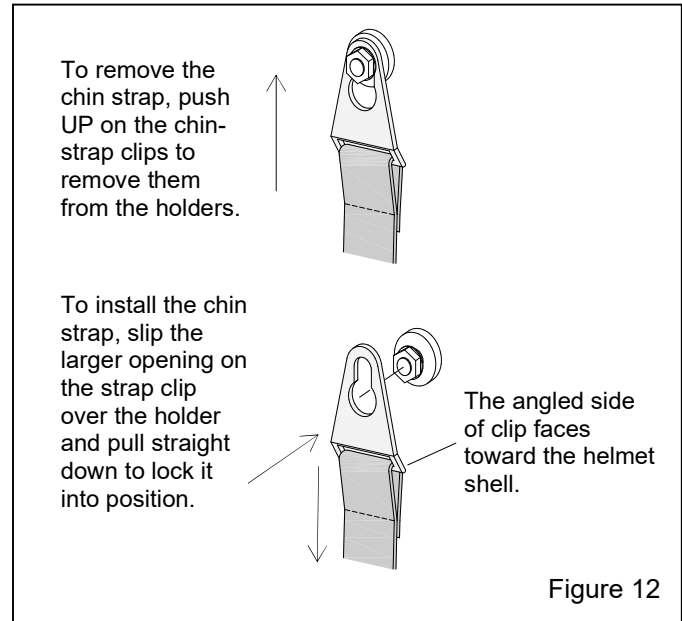

10.7.7 Reattach the cape to the helmet by following the instructions in Section 10.8.

10.8 Remove and Replace the Cape

10.8.1 To ensure correct reattachment of the cape and attachment strap, refer to the cross section in Figure 13. Note that the cape retaining spring is between the helmet retaining grooves, and the strap extends over both rims.

10.8.2 When the cape becomes soiled or requires replacement, it can easily be removed as follows:

10.8.3 Push the release lever on the cape attachment buckle, as shown in Figure 14. While pushing the lever, pull the tensioning strip out of the buckle and remove the attachment strap.

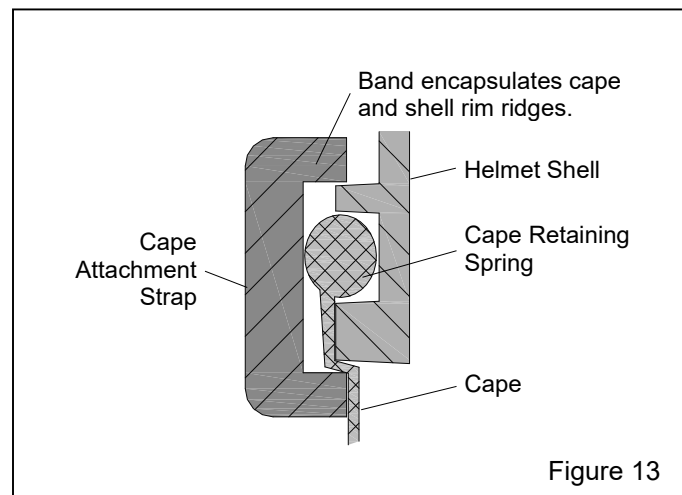

10.8.4 Pull the cape to detach it from the helmet.

10.8.5 Install the cape by stretching it over the lower helmet rim so that the cape spring rests between the ridges, as shown in Figure 13. Position the cape so the back seam aligns with the center of the back of the helmet.

10.8.6 Place the attachment strap over the cape, as shown in Figure 13. When correctly positioned, the buckle is on the window hinge side of the helmet, and the tensioning strip points toward the front.

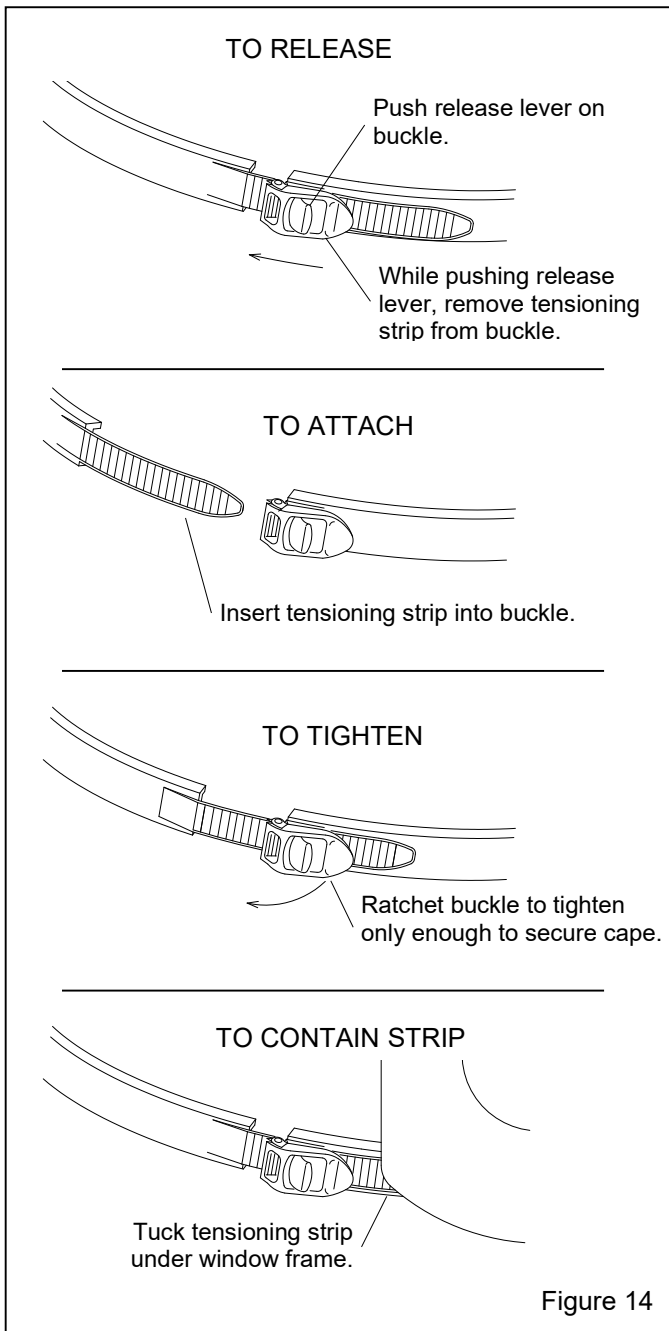

Figure 14

10.8.7 Ratchet the buckle to tighten the strap, making sure the cape and strap remain in position as the strap is tightened. Tighten only enough to secure the cape; overtightening could damage the tensioning strip.

10.9 Remove and Replace the Inner Collar

10.9.1 The inner collar controls air escape from the helmet and prevents ingress of dust.

10.9.2 The elastic properties of the collar provide a snug fit around the user's neck. The inner collar must be replaced before it is stretched to the point where it no longer fits snugly on the user's neck. The collar unzips from the cape for replacement or washing. Refer to Section 8.2 for cleaning instructions.

10.10 Remove and Replace the Window Frame

10.10.1 The window frame or latch must be replaced when it becomes difficult to maintain a seal. When replacing the window frame or latch on a helmet with webbed suspension, the acoustical foam inside the helmet should also be replaced.

10.10.2 Remove the cape, per Section 10.8, and remove the breathing to prevent damage to the tube.

10.10.3 Peel back the front edge of the acoustical foam or remove the DLX side pad to access the window frame screws.

10.10.4 From inside the helmet remove the Philip screws that secure the window hinge to the helmet. The nuts are restrained within the window frame hinge.

10.10.5 Attach a new window frame in reverse order. Replace the acoustical foam or side pad as needed.

10.10.6 Install new intermediate and outer lenses, per Sections 10.3 and 10.4.

10.10.7 Attach the cape and breathing tube.

10.11 Remove and Replace the Window Frame Latch

10.11.1 Remove the cape, per Section 10.8, and remove the breathing to prevent damage to the tube.

10.11.2 Peel back the acoustical foam or remove the DLX side pad to access the latch-base nuts.

10.11.3 Use a 5/16" backup wrench on the nuts and use a Phillips screwdriver to remove the latch base.

10.11.4 Remove the latch from the base.

10.11.5 Replace the latch and base, as needed, and reassemble in reverse order.

10.11.6 Replace the acoustical foam or side pad as needed.

10.11.7 Attach the cape and breathing tube.

10.12 Remove and Replace the Air-Inlet Fitting

10.12.1 Use a wrench to remove the old fitting.

10.12.2 Apply a drop of cyanoacrylate (super glue) to one end of the new fitting and screw the glued end hand-tight into the helmet.

10.12.3 Connect the breathing tube and use the tube for leverage to tighten the inlet fitting. Do not use a wrench to tighten the fitting, as it may damage the helmet. Leave the breathing tube connected until the cyanoacrylate has set.

10.13 Remove and Replace the Air-Channel Partition

10.13.1 Remove the breathing tube, cape per Section 10.8, and suspension per Section 10.6.

10.13.2 Pull the partition to remove it from the helmet.

10.13.3 The new partition has a slight bend on the rounded end; bend the partition to approximately 45 degrees, as shown in Figure 15.

10.13.4 Place the partition within the helmet shell with the bend to the back and pointing toward the inlet fitting.

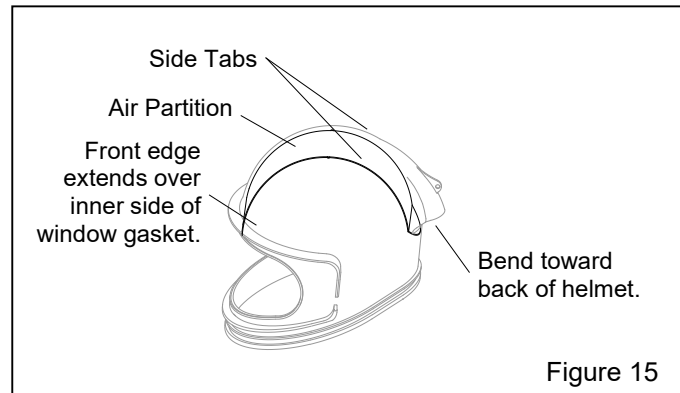

10.13.5 Insert the two side tabs over the positioning tags on the uppermost part of the shell. Press the partition to snap it into place. Working from the center toward the back and front, snap the partition into place between the retaining tags. The front edge of the partition will extend over the window gasket.

10.13.6 Reattach the suspension, cape, and breathing tube.

11.0 REPLACEMENT PARTS

 WARNING

Use of any non-Clemco replacements parts may permit ingress of hazardous contaminants and may cause injury, disease, or death to the user. OSHA Regulation 29 CFR 1910.134(H)(4)(i) requires the use of the respirator manufacturer's NIOSH-approved parts designated for the respirator. Using any parts listed in this section made by any manufacturer other than Clemco voids the NIOSH approval, and voids Clemco's warranty.

11.1 Supplied-Air Respirator Systems

11.1.1 Apollo 20 LP Supplied-Air Respirator Systems: Respirators come with DLX Padded Suspension and Web Suspension. DLX Suspension is installed.

- less respirator hose..... 21299
- with 1/2" x 50 ft respirator hose..... 21423

11.1.2 Apollo 600 LP Supplied-Air Respirators Systems:

- Apollo 600 LP Respirator with Web Suspension
 - less respirator hose..... 24010
 - with 1/2" x 50 ft respirator hose..... 24011
- Apollo 600-LP DLX Respirator with Padded Suspension
 - less respirator hose..... 25195
 - with 1/2" x 50 ft respirator hose..... 25210

11.2 Apollo Accessories

11.2.1 Apollo 20 LP Accessories

Description	Stock No.
Pressure conversion kit, LP to HP Apollo LP, low pressure (ambient air) respirator to high pressure (Grade "D" Compressed Air) respirator	22080
DLX padded suspension kit Includes everything needed to replace padded suspension, or to convert from web suspension to DLX padded suspension	25215
Hearing protection muffs: low profile noise reduction for use with web suspension w/sweatband only. May not work with all head sizes	23886
Do-rag, washable head scarf	23814

11.2.2 Apollo 600 LP Accessories

Description	Stock No.
Pressure conversion kit, LP to HP Apollo LP low pressure (ambient air) respirator, to high pressure (Grade "D" Compressed Air) respirator	22080
Hearing protection muffs: low profile noise reduction for use with web suspension w/sweatband only. May not work with all head sizes	23886
Do-rag, washable head scarf	23814
DLX padded suspension kit includes everything needed to replace padded suspension, or to convert from web suspension to DLX padded suspension	25189

11.3 Apollo 20 Respirator Replacement Parts
Figure 16

Item	Description	Stock No.
1.	Gasket, molded window	99996
2.	Inner lens, 4-5/8" x 6-5/8" nom., .125" package of 5	21409
3.	Middle lens, 5" x 7" nom., .094" package of 5	21410
4.	Cover lens, perforated, .0075" package of 25	21411
5.	Gasket, lens frame	21041
6.	Lens frame	20976
7.	Latch, lens frame, rubber	21298
8.	Button, latch	21040
9.	Screw, #6 x 1/2" for latch, 2 required	21402
10.	Screw, #6 x 1" for latch, 2 required	21403
11.	O-Ring, 7/8" OD, 2 required	22815
12.	Breathing tube assembly, 33" long with two item 11	22811
13.	Partition, air-channel	21118
14.	Chin Strap	04460
15.	Chin strap holder, 2 required	21696
16.	Screw, 8-32 x 1/2" Ph Hd, 2 required	21119
17.	Cape attachment strap	10534
18.	Cape with inner collar	21301
19.	Nut, lens frame, 2 required	90041
20.	Screw, lens frame, 2 required	90295
21.	Belt, 2" web with buckle	04430
22.	Constant-flow connector, LP without belt	21429
	with belt	21777
23.	DLX padded suspension kit includes items 13 and 24 thru 29	25215
24.	Pad, top	25216
25.	Suspension web, DLX	25219
26.	Pad, middle	25182
27.	Pad, side	25218
28.	Velcro® hook tape, adhesive backed, 1-inch x 2-feet long	24655
29.	Do-rag, washable head scarf	23814
30.	Web suspension w/sweatband (alternate)	10532
31.	Respirator hose, 1/2" x 50 ft. (alternate)	22510
	1/2" x 100 ft. (alternate)	21413

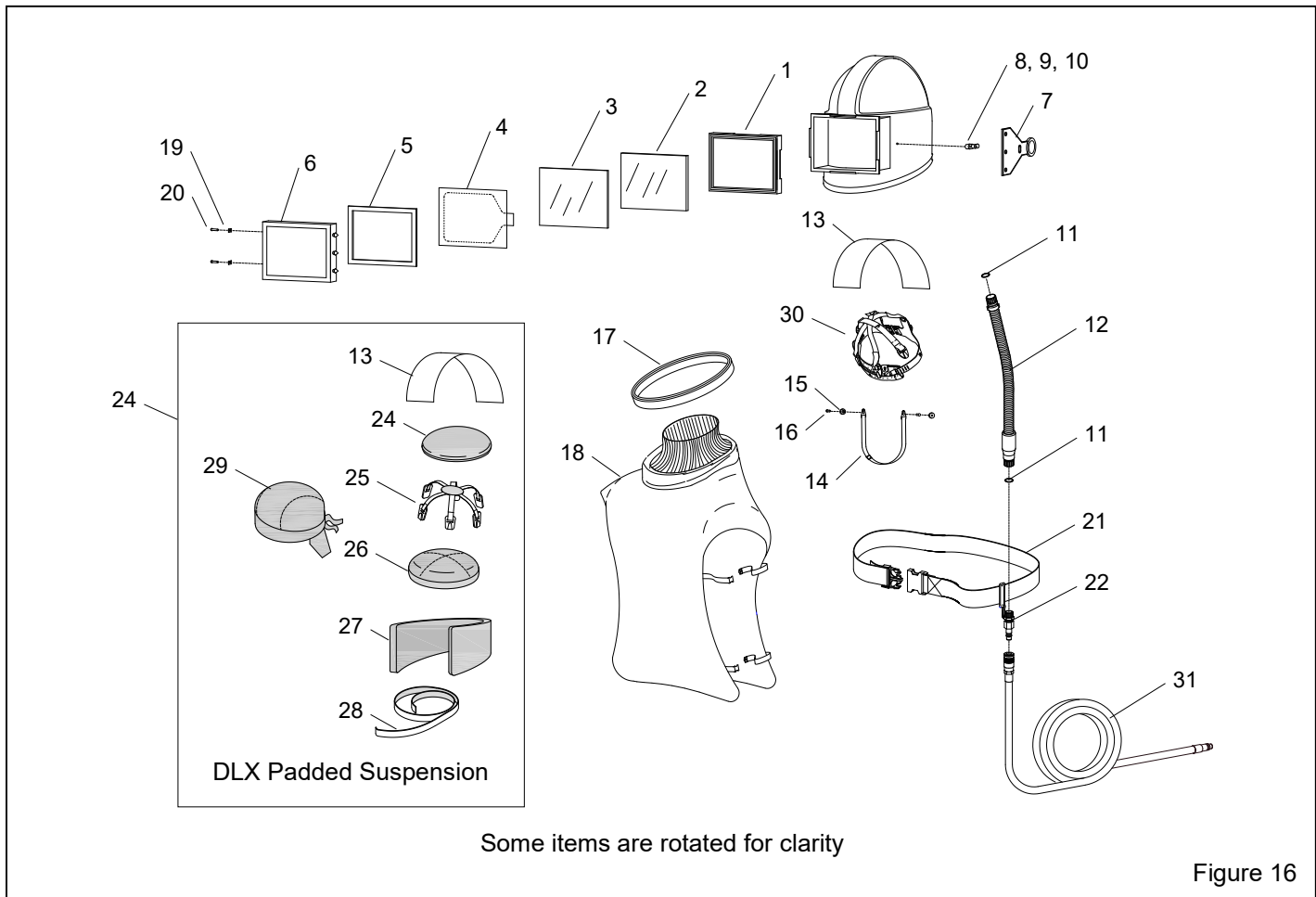

**11.4 Apollo 600 Respirator Replacement Parts
Figure 17**

Item	Description	Stock No.
1.	Gasket, window	23819
2.	Inner lens, .040", package of 5	04367
	value-pack (70 packs of 04367	23065
3.	Intermediate lens, .020", package of 5	24943
	package of 25	04373
	value-pack, (24 packs of 04373)	23067
4.	Outer lens, .0075", perforated, package of 25	04361
	value-pack, (60 packs of 04361)	23064
5.	Window frame assembly	24012
6.	Outer lens, .015", rectangular, pkg. of 25 ..	24005
7.	Acoustical foam kit, both sides not used with padded suspension	04369
8.	Chin strap	04460
9.	Handle strap	03623
10.	Breathing tube assembly, 33" long with two item 11	22811
11.	O-ring, 7/8" OD, 2 required	22815
12.	Partition, air-channel	23811
13.	Chin strap holder kit (2 w/ fasteners)	24008
14.	Cape attachment strap	23801
15.	Cape, Grey with inner collar	23818
16.	Inner collar, cape	08740
17.	Latch kit, window frame includes base, screws and nuts	24006
18.	Inlet fitting, breathing tube	23804
19.	Web suspension with sweatband (alternate)	23802
20.	Sweatband, used with item 19	23817
21.	Clips, suspension (pack of 4)	24773
22.	Belt, 2" web with buckle	04430
23.	Constant-flow connector, LP without belt	21429
	with belt	21777
24.	DLX padded suspension kit (alternate) includes items 12 and 25 thru 30	25189
25.	Pad, top	25181
26.	Suspension web, DLX	25184
27.	Pad, middle	25182
28.	Pad, side black/grey fits most head sizes	25183
	black/blue for smaller head sizes	25187
29.	Velcro® hook tape, adhesive backed, 1-inch x 3-foot long	24656
30.	Do-rag, washable head scarf	23814
31.	Respirator hose, 1/2" x 50- foot (alternate)	22510
	1/2" x 100-foot (alternate)	21413

