

# CA500 Assembly Instructions

## Parts List

(Parts are not actual size)

Please remove all contents from the carton and inspect to ensure quantities are correct and to familiarize yourself with the parts. Please read through all directions prior to starting assembly of the muck cart.

If you should experience any difficulties, issues, or problems while assembling the CA500 Muck Cart we encourage you to first visit our website ([www.miller-mfg.com](http://www.miller-mfg.com)) for the latest assembly tips, color photos, and further instructions. You may also reach customer service during normal business hours at 800-260-0888.

### Tools Required:

- 1/2" wrench/adjustable wrench/socket
- 3/4" wrench/adjustable wrench/socket
- 14mm wrench/adjustable wrench/socket

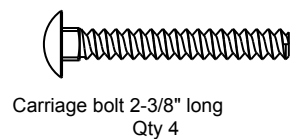
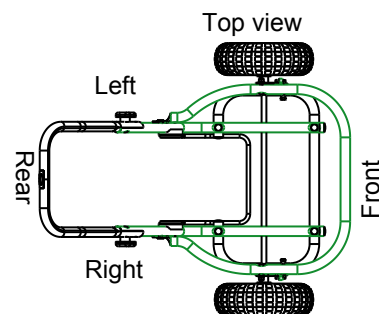
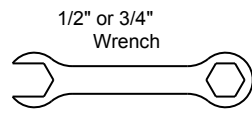
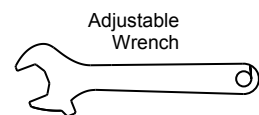

Carriage bolt 2-3/8" long Qty 4



Curved washer Qty 4

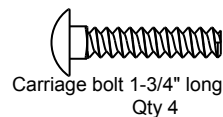

Carriage bolt 1-3/4" long Qty 4

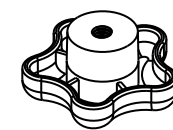

Knob Qty 2



Spacer bushing PREASSEMBLED Qty 2



Small Nyloc nut 4 PREASSEMBLED Qty 8

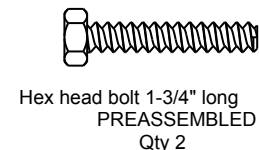

Hex head bolt 1-3/4" long PREASSEMBLED Qty 2

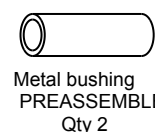

Metal bushing PREASSEMBLED Qty 2

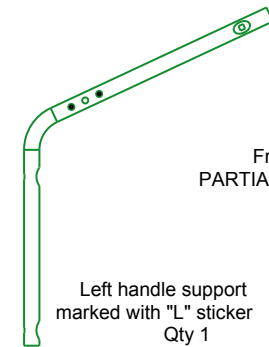

Left handle support marked with "L" sticker Qty 1

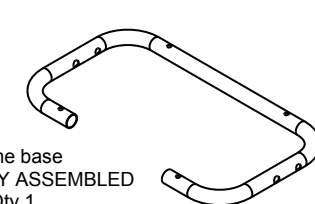

Frame base PARTIALLY ASSEMBLED Qty 1

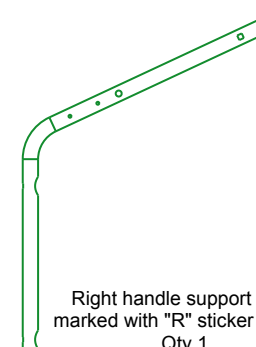

Right handle support marked with "R" sticker Qty 1

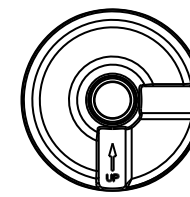

Right kick stand plastic bracket PREASSEMBLED Qty 1

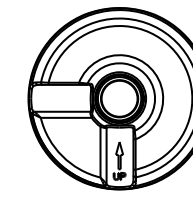

Left kick stand plastic bracket PREASSEMBLED Qty 1



Phillips head screw PREASSEMBLED Qty 4

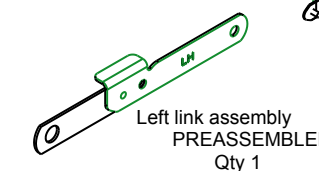

Left link assembly PREASSEMBLED Qty 1

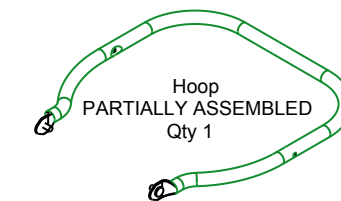

Hoop PARTIALLY ASSEMBLED Qty 1

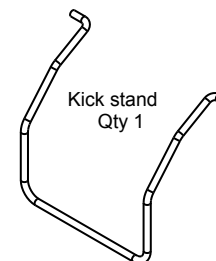

Kick stand Qty 1

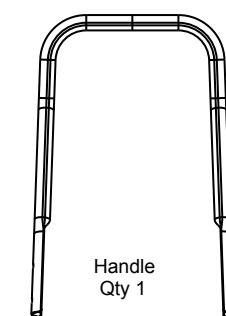

Handle Qty 1



Large Nyloc nut Qty 2

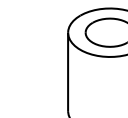

Plastic spacer Qty 2

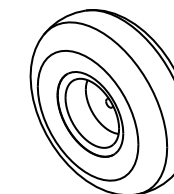

Pneumatic tire Qty 2

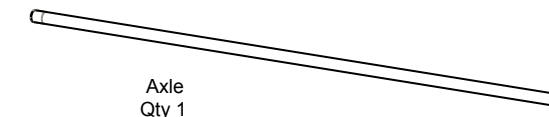

Axle Qty 1

### Notes:

Items assembled together in the hardware bag are used together in the assembly of the muck cart

Items that have been pre-assembled on the muck cart for your convenience:

- The frame base and hoop (connected with the left & right link assemblies - hardware is finger tightened)
- The kickstand plastic brackets

### Parts for step 1

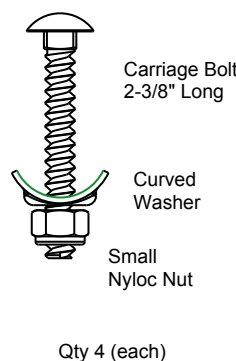

Qty 4 (each)



### 1 ASSEMBLE FRAME BASE TO HANDLE SUPPORT

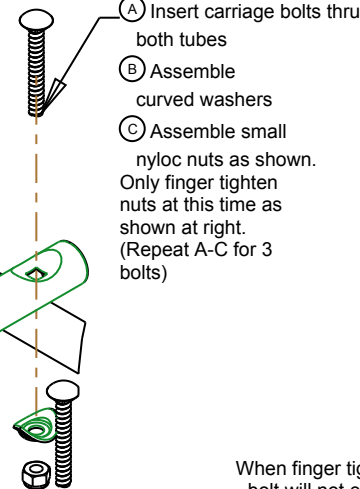

- Insert carriage bolts thru both tubes
- Assemble curved washers
- Assemble small nyloc nuts as shown. Only finger tighten nuts at this time as shown at right. (Repeat A-C for 3 bolts)

### Assembled view

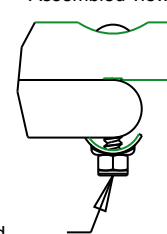

When finger tightened bolt will not extend thru nut.

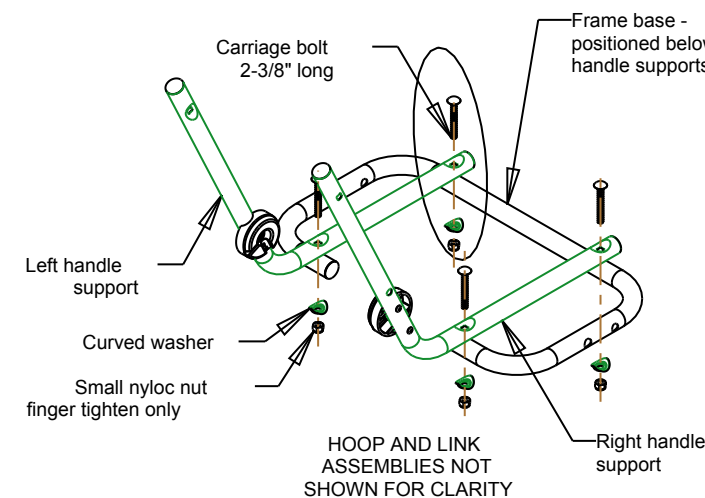

Left handle support

Curved washer

Small nyloc nut finger tighten only

HOOP AND LINK ASSEMBLIES NOT SHOWN FOR CLARITY

Frame base - positioned below handle supports

Right handle support

### Front view of assembly

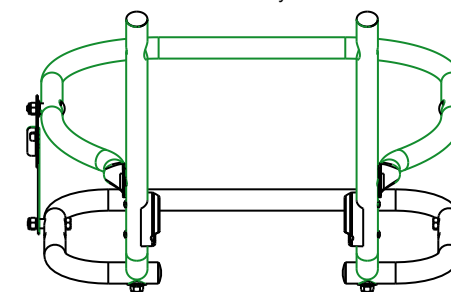

### Parts for step 2

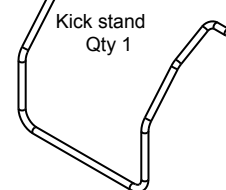

### 2

### ATTACH HOOP TO HANDLE SUPPORTS

- Tighten hardware on left and right link assemblies

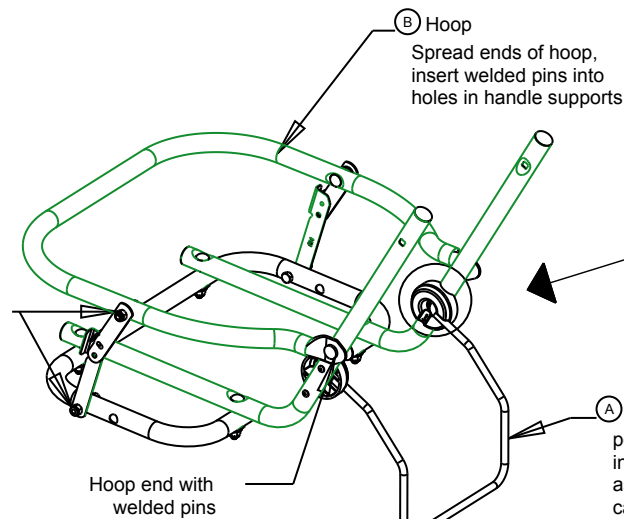

- Hoop Spread ends of hoop, insert welded pins into holes in handle supports

### Plastic bracket

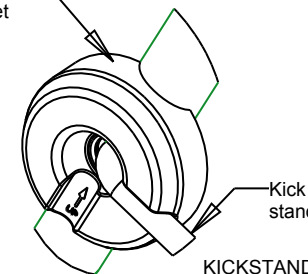

KICKSTAND BRACKET ALREADY PREASSEMBLED SHOWN FOR KICKSTAND DETAIL

- Install kick stand in down position by inserting ends into hole in plastic brackets as shown (May help to lay cart on side to insert kick-stand)

### Parts for step 3

No extra parts are needed for step 3

### 3

### TIGHTEN BOLTS

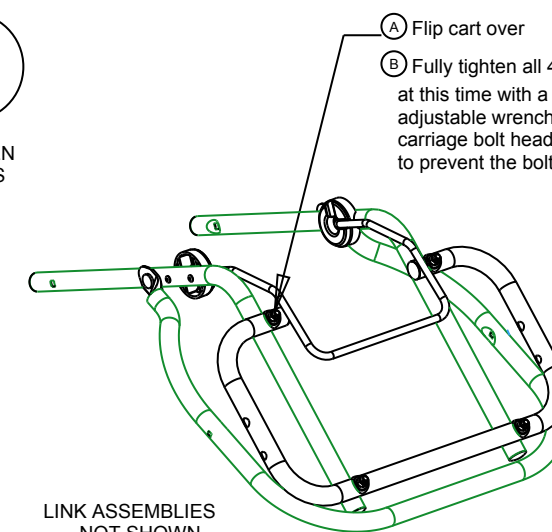

- Flip cart over

- Fully tighten all 4 small nyloc nuts at this time with a 1/2" wrench or adjustable wrench. (Hold the carriage bolt head against frame base to prevent the bolt from turning.)

LINK ASSEMBLIES NOT SHOWN

Assembly instructions continued on page 2.

# Continued assembly instructions for CA500 and operating instructions

**Parts for step 4**

- Carriage Bolt 1-3/4" long
- Knob Plastic
- Qty 2 (each)
- Handle Qty 1

**4**

**INSTALL HANDLE**

(A) Handle  
Handle can be assembled using either the top or bottom holes. For a longer handle use the bottom holes.

(B) Knob

(C) Carriage bolt 1-3/4" long

**Parts for step 5a & 5b**

- Large Nyloc Nut Qty 2
- Pneumatic tire Qty 2
- Axle Qty 1
- Spacer Plastic Qty 2

**5a**

**INSTALL TIRES**

Finger tighten nyloc nut at this time

(D)

(C) Pneumatic tire

(B) Plastic spacer

(A) Axle

Axle and hardware will be partially preassembled. One of the nyloc nuts will be completely assembled on the axle. The second nyloc nut is finger tightened. The two plastic spacers will be on the axle. (Remove the finger tight nyloc and the spacers before assembly.)

**5b**

Nyloc nut (D)

Tighten second nyloc nut by placing one 3/4" wrench on each large nyloc nut and tightening until snug, tires should spin freely after assembly

(C) Pneumatic tire

(B) Plastic spacer

Slide axle assembly through holes in frame base (A)

**Operating Instructions** Visit our website ([www.miller-mfg.com](http://www.miller-mfg.com)) for the latest operating tips, assembly tips, color photos, and further instructions

## Operating tips:

1. The cart can either be pushed or pulled. Pulling cart is recommended for ease of transportation and ability to properly stabilize load.
2. Handle can be assembled using either the top or bottom holes. For a longer handle use the bottom holes.
3. Loosen knob approximately 1/2" to allow handle to pivot forward or backwards for storage.
4. Lower hoop for easy unloading.
5. Lock link assemblies in up position to use hoop as platform for hauling large objects.

## Recommendations:

1. Recommended tire pressure:  
10-20 PSI for normal use,  
30 PSI for maximum load capacity.

**Push or Pull Cart**

Loosen each knob approximately 1/4" - 1/2" to allow handle to pivot forward or backwards for storage

Install carriage bolt and knobs in either hole for handle height adjustability.

Little Giant PSB70

Push tabs to lock hoop in "up" position

**!! WARNING !!**

The CA500 muck cart can become unstable or tip if the hoop is loaded unevenly.

Check link assembly is locked when in the up position when hauling or loading items into or onto the hoop.

Little Giant PSB70

Pull tabs to lower hoop to allow easy unloading

Wall

Hooks not included

Cart shown collapsed for compact storage hanging on wall