

**QUANTUM PNEUMATIC
REMOTE CONTROL SYSTEM
O. M. 25836**

DATE OF ISSUE: 04/03/13
REVISION:

 **WARNING**

Do not proceed with these instructions* until you have READ the orange cover of this MANUAL and YOU UNDERSTAND its contents.

These WARNINGS are included for the health and safety of the operator and those in the immediate vicinity.

***If you are using a Clemco Distributor Maintenance and Part Guide, refer to the orange warnings insert preceding the Index before continuing with the enclosed instructions.**

Electronic files include a Preface containing the same important information as the orange cover.

© 2013 CLEMCO INDUSTRIES CORP.
One Cable Car Dr.
Washington, MO 63090
Phone (636) 239-4300
Fax (800) 726-7559
Email: info@clemcoindustries.com
www.clemcoindustries.com



1.0 INTRODUCTION

1.1 Scope

1.1.1 This manual covers the installation, operation, maintenance, troubleshooting, and replacement parts for Clemco Quantum Pneumatic Pressure-Hold Remote Control System. The following manuals may be used in conjunction with the Quantum system manual. They are available upon request from Clemco Industries Corp., or at our web site at www.clemcoindustries.com.

- Single Chamber Blast MachineManual No. 06160
- Dual Chamber Blast MachineManual No. 06154
- ACE Air ValveManual No. 23938
- RLX Control HandleManual No. 10574
- Quantum Media Metering ValveManual No. 22565

1.1.2 These instructions also contain important information required for safe operation of the blast machine. All blast operator(s) and machine (pot) tenders must be trained in the safe operation of the blast machine, remote control system, and all blasting accessories. Before using the machine, all personnel involved with the blast machine operation must read this entire manual, including the orange cover, and all accessory manuals.

1.1.3 All personnel involved with the abrasive blasting process must be made aware of the hazards associated with abrasive blasting. The Clemco booklet "Abrasive Blasting Safety Practices" is included with every blast machine, and contains important safety information about abrasive blasting that may not be included in equipment operation manuals. Additional copies are available from Clemco Industries.

1.2 Safety Alerts

1.2.1 **Clemco uses safety alert signal words, based on ANSI Z535.4-1998, to alert the user of a potentially hazardous situation that may be encountered while operating this equipment. ANSI's definitions of the signal words are as follows:**



This is the safety alert symbol. It is used to alert the user of this equipment of potential personal injury hazards.

Obey all safety messages that follow this symbol to avoid possible injury or death.

CAUTION

Caution used without the safety alert symbol indicates a potentially hazardous situation which, if not avoided, may result in property damage.

CAUTION

Caution indicates a potentially hazardous situation which, if not avoided, may result in minor or moderate injury.

WARNING

Warning indicates a potentially hazardous situation which, if not avoided, could result in death or serious injury.

DANGER

Danger indicates an imminently hazardous situation which, if not avoided, will result in death or serious injury.

1.3 General Description

1.3.1 The components of the Quantum remote control system are shown in Figure 1. They include the Quantum pneumatically-operated abrasive metering valve, ACE air valve, RLX Control Handle with abrasive cut-off (ACS) air switch assembly, 50-foot twinline control hose, 50-foot single-line control hose, 18-inch hose, 3-foot and 5-foot control hose, and all necessary fittings.

1.3.2 The remote control system is an OSHA-required safety device. The control handle, located near the blast nozzle, is the activator for the remote control system. When the operator intentionally or unintentionally removes hand-held pressure from the remote control handle, the abrasive metering valve and air valve close, stopping air and abrasive flow through the nozzle. The remote control system "fails to safe", which means when any interruption in the control-air circuit occurs, for reasons such as a break in the line, the compressor stops running, or the operator drops the blast hose, the remote control stops the blasting.

WARNING

Never modify or substitute remote control parts. Parts from other manufacturers are not compatible with Clemco equipment. If ANY part of the remote control system is altered, involuntary activation, which may cause serious injury, can occur.

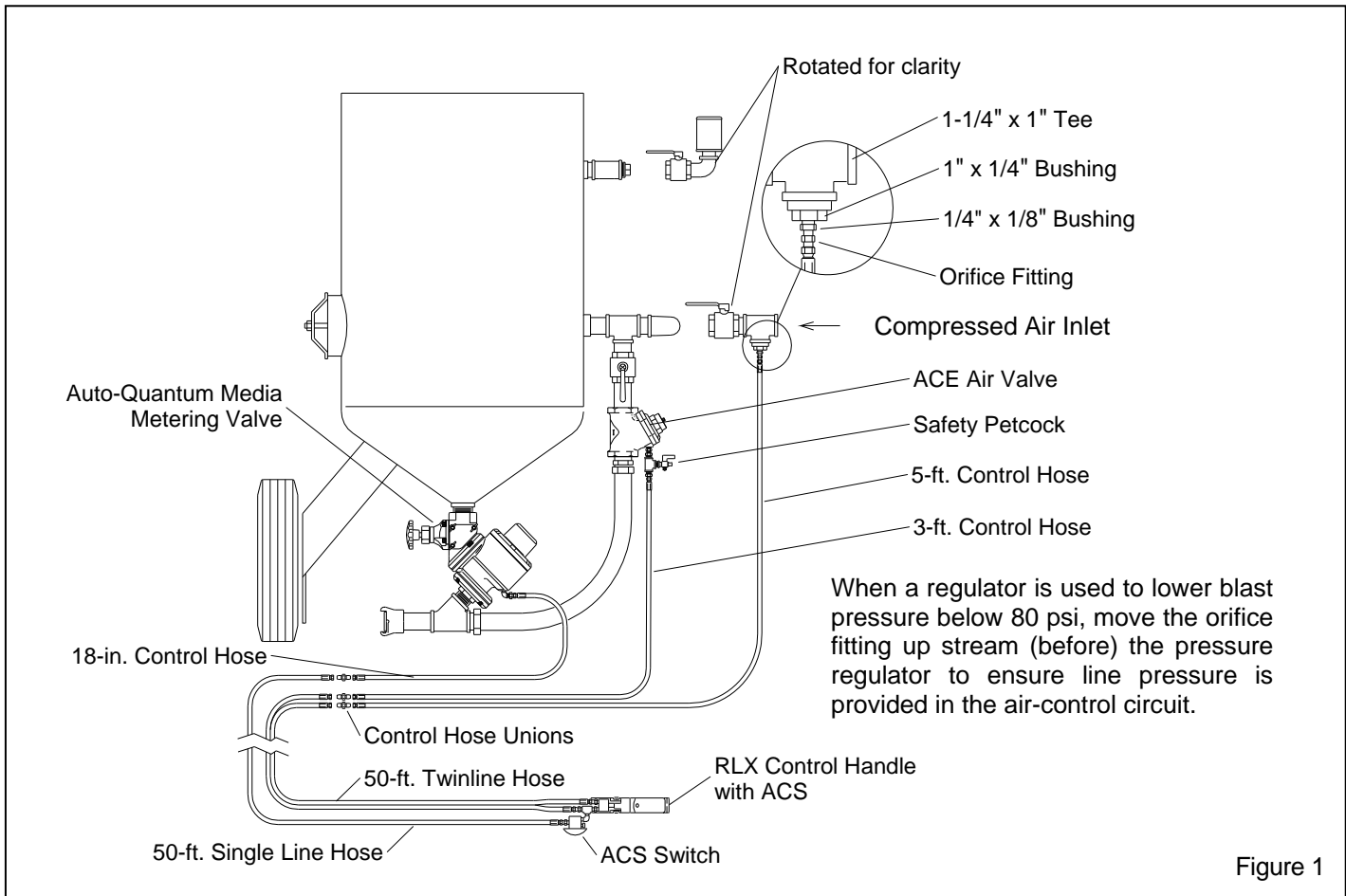

Figure 1

1.4 Operating Principles

1.4.1 Quantum remote controls are pressure-hold type systems. This means that pressurization and depressurization of the blast machine is a separate function from the remote controls. Using hand operated inlet and outlet valves, the operator manually pressurizes and depressurizes the blast machine. Although the machine is under pressure neither air nor abrasive exits from the nozzle because the normally closed (NC) Quantum valve shuts off abrasive flow, and the ACE air valve shuts off air flow. Blasting will not start until the operator activates the control handle. Pressure remains in the blast machine until it is manually depressurized.

1.4.2 Compressed air enters the blast machine through the inlet piping, and is split into three streams. One stream goes directly into the blast machine, the second stream goes into the pusher-line, and the third stream is the control air used to operate the remote controls.

1.4.3 Quantum remote controls operate on the "return air" principle (refer to Figure 1). When the machine is manually pressurized, control air travels from the orifice, down the outbound twinline and escapes through an opening located under the control handle lever. As long as air escapes through the opening, the

remote control system remains inactive. When the control handle lever is pressed, the a rubber button seals the opening, and air from the outbound line returns through the inbound twinline, opening both the abrasive metering valve and air valve to start the blasting process. Releasing the handle exhausts the control air, causes the valves to close and blasting stops.

1.4.4 An abrasive cut-off switch (ACS) is a standard feature of the Quantum remote control. The abrasive cut-off switch is mounted on the control handle. The operator uses the switch to close the abrasive valve independently of the air valve, so air without abrasive exits the nozzle to clear the blast hose or to blow-down the surface.

1.5 Electric Control Option

1.5.1 Electric remote controls (electro-pneumatic) are recommended when the nozzle and remote control handle are farther than 100 feet from the blast machine. Pressure drop of pneumatic systems over longer distances increases actuation time, which prevents fast, safe operation. Contact your local Clemco Distributor for more information.

2.0 INSTALLATION

2.1 Factory Installation: If the remote control system was factory installed, skip Section 2.2 and make the connections described in Section 2.3.

2.2 Field Installation: Refer to Figures 2 and 3.

2.2.1 Empty the blast machine of abrasive. Depressurize the machine. Shut down the compressed air source. Disconnect the air supply line; and lockout and tagout the air supply.

⚠ WARNING

Depressurize the blast machine, lockout and tagout the compressed air supply, and bleed the air circuit before performing any maintenance on the machine or pneumatic accessories. Failure to do so could cause severe injury or death from the sudden release of trapped compressed air.

2.2.2 Remove the existing abrasive metering valve and all external piping from the blast machine.

NOTE: To ensure airtight seals, use pipe sealant on all male pipe threads.

2.2.3 Install the 1-1/4" outlet nipple and wye on the metering valve, and position them as shown in Figure 2.

NOTE: The following describes installation of the Quantum valve on a machine with minimal rotation clearance. If the valve assembly will freely rotate beneath the blast machine, it may be installed as a unit.

2.2.4 Remove the four socket head screws holding the metering assembly to the actuator, and remove the actuator assembly as shown in Figure 2.

2.2.5 Use the 1-1/2" x close, schedule 80 pipe nipple to connect the metering segment to the outlet coupling at the bottom of the blast machine. Position the metering knob as shown in the illustrations.

2.2.6 Make sure the flange gasket is in place, and bolt the actuator to the metering segment.

2.2.7 Install a 1-1/4" pipe tee (Tee No.1) at the blast machine inlet as shown in Figure 3.

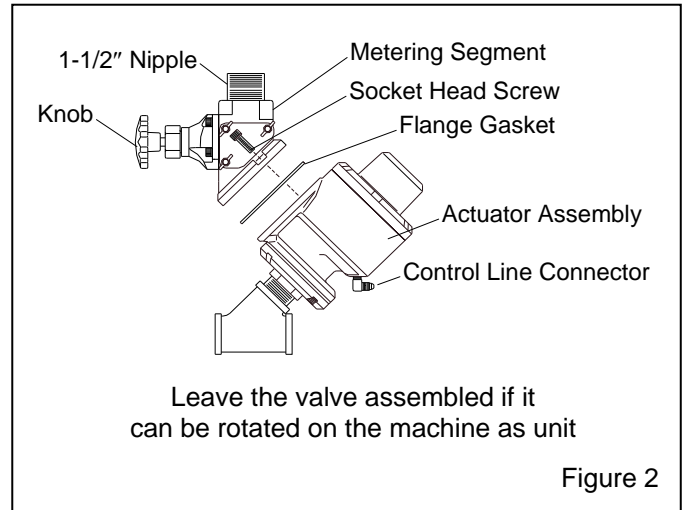

2.2.8 Assemble a pusher-line between the tee fitting and the Quantum valve using standard pipe fittings or flexible pusher-line as shown in Figure 3. Start at the tee and work downstream; this line must include a manual choke valve and the ACE air valve, in that order.

2.2.9 Connect a manually operated ball valve (inlet valve) and a second tee (Tee No. 2) to the blast machine as shown. NOTE: The second tee and all fittings necessary to complete the assembly shown in the detail circle in Figure 1 are included with the remote system.

2.2.10 Refer to the detail circle in Figure 1, and install the bushings and 1/16" orifice fitting.

2.2.11 Assemble a manual outlet valve assembly, and install it as shown. NOTE: Clemco supplies an exhaust muffler with all blast machines 1.5 cubic feet and larger. The muffler reduces exhaust noise and directs the exhaust downward, which prevents abrasive from exhausting into the air. When the blast machine is depressurized, the muffler body will pop up and diffuse the escaping air and abrasive. When the machine is fully depressurized, the muffler body will drop, permitting trapped abrasive to empty. For the muffler to work properly, it must be installed with the body facing up, as shown in Figures 1 and 3.

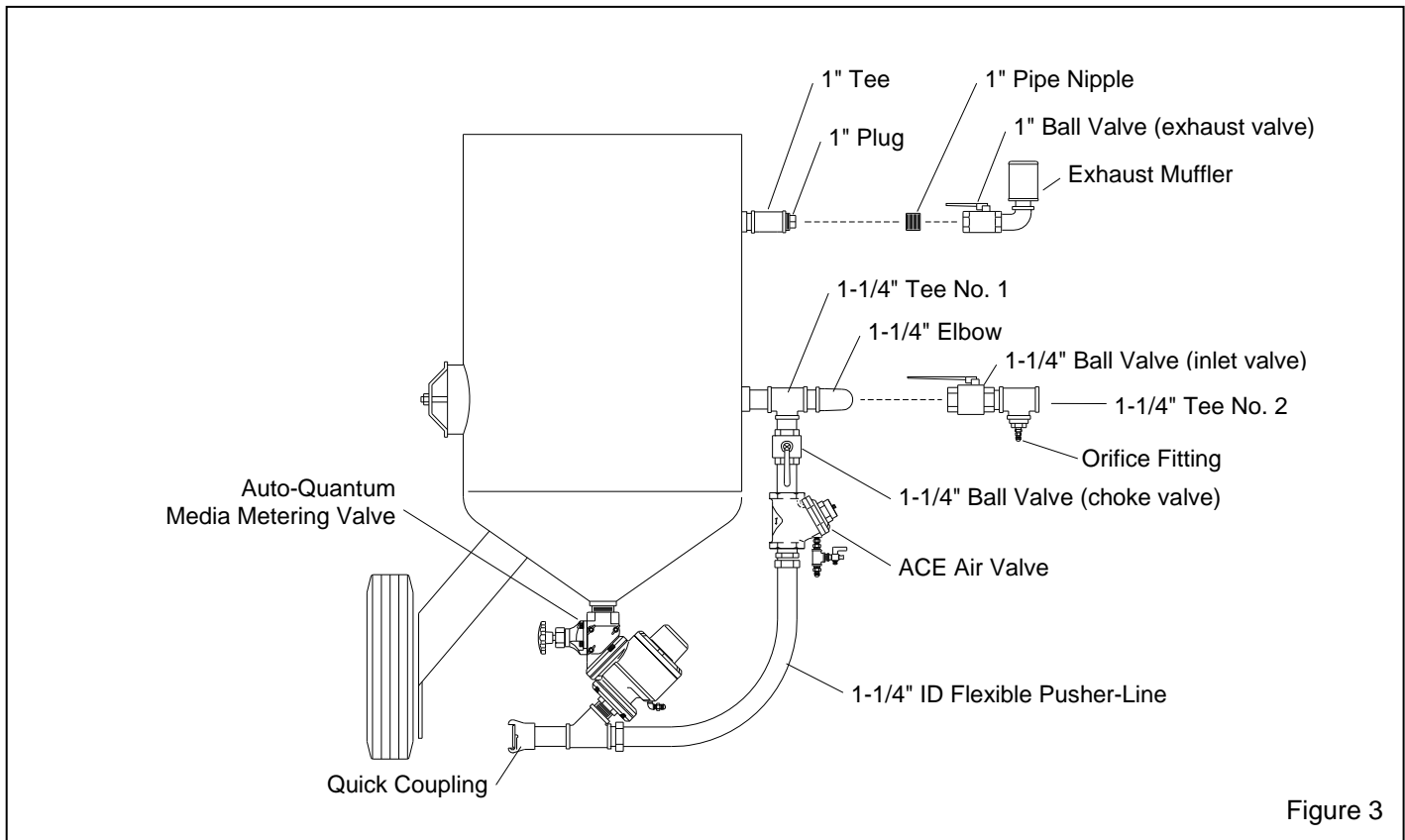

Figure 3

2.3 Blast Hose and Control Hose Connections
Refer to Figure 1.

NOTE: The following instructions explain the connections on a single operator blast machine and remote control system. Connections for dual operator machines are the same except the connections must be made twice; once for operator #1 and again for operator #2. Controls for operator #1 and #2 must be kept separate. Read the following warning before making the connections.

WARNING

Carefully trace, connect, and mark, control lines and blast hose on multiple-outlet blast machines, or where two or more blast machines are used. Switching control lines or blast hose, could lead to injury and property damage from unintentional actuation of a blast machine. To reduce the possibility of hose switching, blast hose and control cord should be of equal lengths. Hose identification kits, part no. 15890 for two outlets, or part no. 15891 for up to four outlets should be used where multiple blast hose and control lines are in use.

2.3.1 Uncoil and stretch out the blast hose and lay the 50-foot twinline hose and 50-foot single line hose alongside it.

WARNING

The fittings used in the tee assembly shown in Figure 1 must have a 1/16" orifice in the end that threads into the bushing. Never use fittings that do not have the 1/16" restricting orifice. Any other fitting will cause accidental actuation of the blast machine which can result in property damage, injury, or death.

2.3.2 Band the control handle to the blast hose at a suitable, comfortable position behind the nozzle holder, using the two nylon ties provided. The tie ends should be clipped so they will not snag the operator's clothing or interfere with the operation of the control handle.

2.3.3 Attach the 50-foot single line control hose to the ACS cut-off switch mounted on the control handle.

2.3.4 Attach the 50-foot twinline hose to the two fittings on the control handle. Either leg can be coupled to either fitting.

2.3.5 Working from the control handle back, band or tape the twinline and single-line hoses to the blast hose every four to six feet.

2.3.6 Attach the blast hose to the blast machine. Use safety lock pins or wires to securely lock the couplings.

2.3.7 Screw the three hose unions into the unattached fittings of the twinline and single-line hose.

2.3.8 Connect the 18-inch control hose between the Quantum valve and the union on the 50-foot single line.

2.3.9 Connect the 5-foot control hose between the orifice fitting on the inlet tee and either one of the unions on the twinline hose.

2.3.10 Complete the control hose connections by connecting the 36-inch control hose between the ACE air valve and the remaining union on the twinline hose.

2.3.11 Band the control hoses on the blast machine side of the unions to the quick coupling nipple.

3.0 OPERATION

3.1 Start-Up

3.1.1 Make sure the control handle is in the up (no-blast) position and that it moves freely. Make sure it will not engage unless the safety lock is pulled down.

WARNING

Malfunctioning control handles could cause unintentional actuation of a blast machine, or prevent a machine from deactivating upon release. Malfunctioning control handles must be taken out of service immediately and repaired or replaced.

3.1.2 Make sure that all hose connections are secure. Install safety lock pins between all quick coupling. Use lock pins and safety cables on all quick coupling connections to help prevent accidental separation of hoses.

3.1.3 Connect the blast machine to an adequate air supply. The compressor should be located upwind from the blasting operation to prevent dust from entering the compressor intake.

3.1.4 Make sure the safety petcocks on the Quantum metering valve and ACE air valve are open. The ACS feature requires two separate control lines, one for the Quantum and one for the ACE valve. To prevent actuation of either valve, both safety petcocks must be open.

WARNING

To prevent severe injury or death from accidental activation of the blast machine, open both safety petcocks when the blast machine is not in use. The control handle will not activate the machine when the petcocks are open.

3.1.5 Start the compressor, and bring it up to operating temperature and pressure. The pressure must be more than 80 pounds per square inch (psi) but not more than the maximum working pressure rating of the blast machine.

3.1.6 Close the outlet valve, and open the inlet valve. The machine will pressurize.

3.1.7 Close the safety petcocks. Air should be heard escaping from the orifice under the control handle lever but nowhere else.

3.2 Blasting Attire

3.2.1 Operators and anyone else exposed to the hazards generated by the blasting process must wear appropriate protective gear, including abrasive-resistant clothing, leather gloves, eye and hearing protection, and a NIOSH-approved Type CE Supplied-Air Respirator.

WARNING

Before blasting, test the coating and substrate for toxic materials (such as lead or other heavy metals, or asbestos). These hazards require special measures to protect the operators and the environment.

No dust is safe to breathe. Abrasive blasting produces harmful dust. Failure to wear approved respirators could result in serious lung disease or death. Blast operators must wear properly fitted and maintained NIOSH-approved, type-CE supplied-air respirators approved for abrasive blasting.

During abrasive blasting, abrasive particles and dust in the area around the blast machine and blast nozzle become airborne. Everyone working in the vicinity of abrasive blasting must wear properly-maintained, NIOSH-approved, respiratory protection appropriate for the job site hazards.

Loud noise generated by the use of compressed air could cause hearing damage. Everyone in the blasting area must wear approved eye and hearing protection.

3.3 Start Blasting

3.3.1 The toggle on the ACS switch should point away from the nozzle. See Operation ACS in Section 3.6.

3.3.2 Hold the blast hose securely and point the nozzle only toward objects intended to be blasted.

3.3.3 Pull back the safety lever lock and depress the remote control handle. Be prepared for blasting to begin within a few seconds.

CAUTION

Be prepared for the recoil from the blast hose. Blasting should begin within a few seconds after pressing the control handle lever.

WARNING

OSHA requires the use of remote controls on all blast machines. To comply with OSHA regulations, the remote control handle, which starts and stops the flow of air and abrasive, must be held down manually. Do not tie down the control handle lever or attempt to bypass any part of the remote control system. Doing so will defeat the purpose of the fail-to-safe feature of the remote control. Serious injury or death could result from uncontrolled blasting. Ref. 29 CFR 1910.244 (b)

3.3.4 Adjust abrasive flow per Section 4.1.

3.4 Stop Blasting

3.4.1 Before releasing the control handle, the operator may use the ACS to shut off the abrasive flow to clear the blast hose, or blow-down the blast surface. See Section 3.6.

3.4.2 To stop blasting, release the control handle lever. The control handle safety lever will flip up to lock the handle lever in the up (no blast) position to prevent accidental activation of the blast machine.

3.4.3 Open the safety petcocks located on the ACE air valve and Quantum metering valve. Always open the safety petcocks during work breaks to prevent unintentional blasting.

3.4.4 It is not necessary to depressurize the machine between short blasting pauses. The media valve and air valve close when the control handle lever is released. To

prevent accidental activation, depressurize the blast machine before any work break.

3.5 Depressurize the Blast Machine

3.5.1 Close the manual inlet valve.

3.5.2 Open the manual outlet valve. The machine will depressurize and the pop-up valve will open.

3.6 Operation of Abrasive Cut-Off Switch

3.6.1 The abrasive cut-off switch is situated directly behind the control handle. The ACS valve is "OFF" (no abrasive) when the toggle position is toward the nozzle ("EXH" port). Abrasive flow is "ON" when the toggle position is away from the nozzle ("CYL" port).

3.6.2 Moving the switch to the "OFF" (forward) position cuts off the air supply to the abrasive metering valve, closes the valve and stops the abrasive flow. This action allows air alone to exit the nozzle, useful for clearing the blast hose before shut-down and blowing abrasive off the blasted surface. The switch can be opened or closed any time but will not activate the metering valve unless the control handle is pressed.

NOTE: The purpose of the ACS is to clear the blast hose and to blow abrasive off the blasted surface at the blasting area. Small amounts of abrasive may come out the nozzle with the air. Residual abrasive may remain that will have to be removed outside the blast area prior to painting.

WARNING

People and the environment tolerate only limited amounts of toxic materials. OSHA limits these exposure levels. Airborne dust could increase the exposure levels beyond permissible limits. OSHA prohibits blowing with compressed air as a cleaning method for lead based paint dust or other hazardous dust, unless the compressed air is used in conjunction with a ventilation system designed to capture the volume of airborne dust created by the compressed air, 29 CFR 1926 (h). The ACS is only for blowing off abrasive from a blasted surface, NOT as a general area clean-up tool.

4.0 ADJUSTMENTS

4.1 Abrasive Metering

4.1.1 Adjust abrasive flow by turning the knob on the metering valve located at the bottom of the blast machine.

4.1.2 The hole in the knob is a rotation reference enabling the operator to monitor its rotation and count turns as the knob is rotated. The reference hole helps return the setting to its original position, should temporary adjustments be required.

4.1.3 The valve is closed when the knob has been turned fully clockwise. Begin with the knob set 1-1/2 turns from fully closed. To increase abrasive flow, the machine tender turns the knob no more than 1/4 turn counterclockwise while the operator is blasting. Allow 10 to 15 seconds for the flow to stabilize before readjusting. Continue making adjustments as described until the correct flow is attained. The valve is fully open when the knob is turned fully counterclockwise.

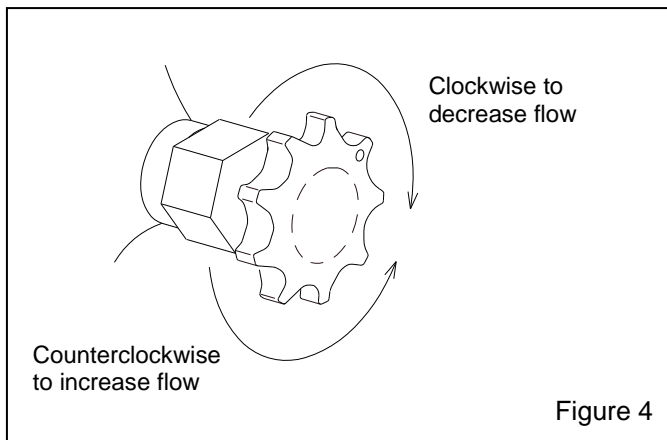

Figure 4

4.1.4 Optimum abrasive flow depends on the type and size of abrasive and blasting pressure, and can best be determined by experience. Use as little abrasive as possible while maintaining the maximum cleaning rate. The air/abrasive mixture should be mainly air. As a rule, the stream of abrasive coming out of the nozzle should barely discolor the air when seen against a contrasting background.

5.0 PREVENTIVE MAINTENANCE

NOTE: These preventive maintenance instructions pertain to the remote controls only. Read the owners' manuals for the blast machine and all blast accessories, for inspection and maintenance schedules of those items.

5.1 Daily

5.1.1 With the air off, before beginning blasting, inspect the following:

Inspect the RLX Control Handle; look for the following:

- The lever must not seal the opening on the control unless the safety lever lock is pulled down.
- The **handle lever** must return to the "up" position when released.
- The **safety lever lock** must return to the "up" position when the handle lever is released.
- Both the handle lever and safety lever lock must move freely with no drag or binding.

⚠ WARNING

Malfunctioning control handles could cause unintentional actuation of a blast machine, or prevent a machine from deactivating upon release. Malfunctioning control handles must be taken out of service immediately and repaired or replaced. Serious injury or death could result from unintentional blasting.

5.1.2 While blasting, check the control handle for leaks.

5.2 Weekly

5.2.1 While blasting, inspect all control hoses, and valves for leaks. If leaks are found, stop blasting and repair.

5.3 Periodic Inspection

NOTE: Periodic inspection of the following items will prevent unscheduled down-time.

5.3.1 The remote control system is a safety device. For safety and to avoid unscheduled down-time, inspect the internal parts of the Quantum valve and ACE air valve. Inspect them for wear and lubrication of O-rings, pistons, springs, seals, and castings. Refer to the individual owner's manuals for equipment listed in Section 6.

5.3.2 The control handle is the actuator of the remote control system. Periodically clean around the springs, handle lever, and safety lever lock to ensure that the unit is free of abrasive and debris that could cause the handle lever or safety lever lock to bind. Refer to the RLX owner's manual for service instructions.

6.0 SERVICE MAINTENANCE

WARNING

Failure to observe the following before performing any maintenance could cause serious injury or death from the sudden release of trapped compressed air.

- Depressurize the blast machine.
- Lockout and tagout the compressed air supply.
- Bleed the air supply line to the blast machine.

6.1 Quantum Metering Valve

Refer to the Quantum valve owner's manual, No. 22565 for service instructions for the Quantum metering valve.

6.2 ACE Air Valve

Refer to the ACE air valve owner's manual, No. 23938 for service instructions for the air valve.

6.3 RLX Control Handle

Refer to the RLX control handle owner's manual, No. 10574 for service instructions for the control handle.

7.0 TROUBLESHOOTING

NOTE: This section only identifies conditions and problems in the remote control system. Always refer to the appropriate section of this manual, or manuals for accessory equipment when troubleshooting the equipment.

WARNING

To avoid serious injury, observe the following when troubleshooting the machine and remote controls.

- Turn off the compressed air, and lockout and tagout the air supply.
- When checking the controls requires air, always enlist the aid of another person to operate the control handle while holding the nozzle securely and pointing it in a safe direction.
- Never strap the remote control handle lever down in the operating position.

7.1 Blasting Does Not Start When the Control Handle Lever is Pressed.

7.1.1 Make sure the safety petcock is closed.

7.1.2 Check for air leaks in all control lines and fittings.

7.1.3 Check for air escaping from the orifice under the control handle. If no air is escaping, the orifice fitting or the line to the handle is plugged.

7.1.4 Open the safety petcocks, and press the control handle lever. Air should come out of the petcocks. If it does not, either the orifice under the lever is not being sealed, or the lines between the handle and the petcocks are blocked.

7.2 Air Continues to Leak From the Nozzle After the Control Handle Lever is Released.

7.2.1 Close the choke valve. If the leak stops, the problem is in the ACE air valve or a blockage in the control line between the air valve and control handle. If the leak continues, the Quantum requires service, or there is a blockage in the control line between the Quantum and the control handle.

7.3 Heavy Abrasive Flow.

7.3.1 Adjust the metering valve per Section 4.1.

7.3.2 Make sure the choke valve is open.

7.3.3 Inspect the metering plate in the Quantum valve for wear. Refer to the Quantum valve owner's manual for service instruction for the Quantum metering valve.

7.3.4 Inspect diaphragm in the ACE air valve for damage.

7.4 Abrasive Flow Does Not Stop When the ACS Toggle is Forward Toward the Nozzle.

7.4.1 Check the exhaust port on the front of the ACS switch, air should momentarily exhaust from the port when the ACS toggle is moved from the back position to the forward position. If it does not, check the following:

- Remove the muffler and check for blockage.
- Obstruction in the air line between the Quantum valve and ACS switch. Check for obstruction.
- Faulty ACS switch.
- Worn seat or plunger in Quantum valve. Inspect valve for wear.

7.5 Air Flow, but No Abrasive.

7.5.1 Make sure the machine contains abrasive.

7.5.2 Make sure the Quantum valve is not closed. The valve is closed when the knob is turned fully clockwise.

7.5.3 Make sure the ACS switch is in the blast position (toggle pointing away from nozzle) Refer to Section 3.6.

7.5.4 Check for a leak or blockage in the hose or fittings from the control handle to the Quantum valve.

7.5.5 The Quantum valve may require service. Refer to the Quantum valve owner's manual.

7.5.6 Use the following methods to check for obstruction in the Quantum valve.

7.5.6.1 Fully open the metering valve. The valve is full open when the knob is turned fully counterclockwise. While blasting, close the choke valve to force out small obstructions or wet abrasive.

 **WARNING**

Depressurize the blast machine, and lockout and tagout the air supply before continuing.

7.5.6.2 For large obstructions shut down the machine to examine the Quantum valve. Remove the inspection plate from the flanged adaptor and clear obstruction.

 **WARNING**

Do not stick fingers into the piston area of the inspection opening. The piston is under spring pressure, and could suddenly close when the obstruction is cleared.

7.6 Abrasive Flow Does Not Stop After the Control Handle Lever is Released.

7.6.1 The control air may not be exhausting from the Quantum valve or control handle. Refer to the RLX control handle manual.

7.6.2 If an ACS is used, check the exhaust filter on the ACS switch for blockage.

7.6.3 Inspect Quantum plunger and valve seat for wear or obstruction. Refer to the Quantum valve owner's manual.

7.7 Quantum Metering Knob Will Not Move.

7.7.1 Damp or hardened abrasive has packed around metering plate. Disassemble valve to inspect and clean.

7.8 Air Leaks Through Relief Hole in Quantum Valve Cylinder Cover.

7.8.1 Replace worn piston cup.

8.0 REPLACEMENT PARTS

8.1 Quantum Remote Control Systems

Item	Description	Stock No.
(-)	Quantum Pneumatic Single-Operator	25834
(-)	Quantum Pneumatic Dual-Operator	25835

8.2 Quantum Remote Control System Replacement Parts, Figure 5

Item	Description	Stock No.
1.	Auto Quantum metering valve with 1-1/4" wye, standard	24447
	with 1-1/2" wye, for 1-1/2" piping	25281
2.	ACE 1-1/4" air valve, standard valve only, without fittings	24074
	valve assembly with fittings	24044
	ACE 1-1/2" air valve, for 1-1/2" piping valve only, without fittings	25288
	valve assembly with fittings	25289
3.	RLX Control handle assembly, complete with ACS	07625

4.	Union, twinline hose (3 required)	01944
5.	Adaptor, 1/8" NPT w/ 1/16" orifice	01945
6.	Hose, twinline, 50-ft. coupled	01951
7.	Hose, single line, 50-ft, 3/16" coupled	03087
8.	Hose, 5-ft. coupled	03083
9.	Hose, 18" coupled	02454
10.	Hose, 3-ft. coupled	02498
11.	Tee, 1-1/4" x 1" pipe	01811
12.	Bushing, 1" x 1/4"	02023
13.	Bushing, 1/4" X 1/8" brass	02010
14.*	Tee, 2" x 1"	01812
15.*	Nipple, 1/4" close	01829
16.*	Tee, 1/4"	01785
17.	Nylon tie	02195
*	Used on dual controls only	

8.3 Valve Replacement Parts

NOTE: Refer to the following manuals for replacement parts for the Quantum Valve, ACE Air Valve, and RLX Control Handle:

- Quantum Abrasive Metering Valve . Manual No. 22565
- ACE Air Valve Manual No. 23938
- RLX Control Handle Manual No. 10574

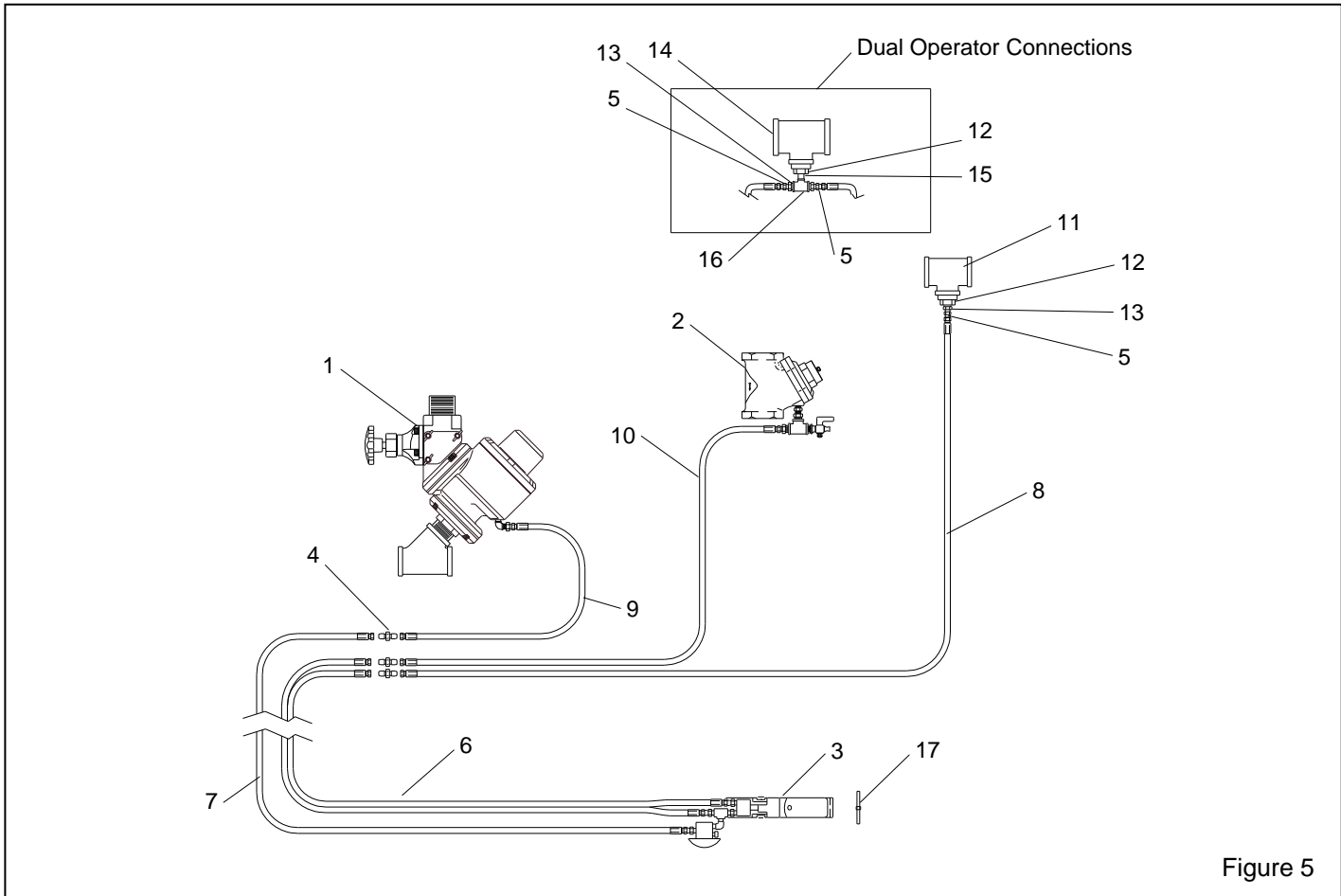

Figure 5