

**CMS 1  
CARBON MONOXIDE MONITOR  
O. M. 23301**

**DATE OF ISSUE: 05/01  
REVISION: H, 02/23**

 **WARNING**

**Do not use this equipment before **READING** this **MANUAL** and **UNDERSTANDING** its contents.**

**These **WARNINGS** are included for the health and safety of the operator and those in the immediate vicinity.**

**Electronic files include a **Preface** containing the same important information as in the orange cover.**

© 2018 CLEMCO INDUSTRIES CORP.  
One Cable Car Dr.  
Washington, MO 63090  
Phone (636) 239-4300  
Fax (800) 726-7559  
Email: [info@clemcoindustries.com](mailto:info@clemcoindustries.com)  
[www.clemcoindustries.com](http://www.clemcoindustries.com)



**1.0 INTRODUCTION**

**1.1 Scope of Manual**

1.1.1 These instructions cover the setup, operation, maintenance, troubleshooting, and replacement parts for the CMS-1 carbon monoxide (CO) monitor.

1.1.2 The CMS-1 monitor is manufactured by Invertech Inc. for Clemco Industries Corp. The monitor is a potential life saving instrument. To assure its performance, the monitor must be properly installed, tested, calibrated, and maintained. Before installing and using the monitor, all personnel involved with the operation and maintenance of the instrument must read this entire manual, including the orange cover.

**1.2 Safety Alerts**

1.2.1 Clemco uses safety alert signal words, based on ANSI Z535.4-2011, to alert the user of a potentially hazardous situation that may be encountered while operating this equipment. ANSI's definitions of the signal words are as follows:



**This is the safety alert symbol. It is used to alert you to potential physical injury hazards. Obey all safety messages that follow this symbol to avoid possible injury or death.**

**NOTICE**

**Notice indicates information that is considered important, but not hazard-related, if not avoided, could result in property damage.**

**CAUTION**

**Caution indicates a hazardous situation that, if not avoided, could result in minor or moderate injury.**

**WARNING**

**Warning indicates a hazardous situation that, if not avoided, could result in death or serious injury.**

**⚠ DANGER**

**Danger indicates a hazardous situation that, if not avoided, will result in death or serious injury.**

**1.3 Table of Contents**

SUBJECT	SECTION LOCATION
<b>INTRODUCTION</b> .....	<b>1.0</b>
Scope of Manual .....	1.1
Safety Alerts .....	1.2
Table of Contents .....	1.3
Components .....	1.4
Operating Principles .....	1.5
Annunciator Lights and Alarms, Use and Functions ...	1.6
Digital Display Window .....	1.7
Switches, Use and Functions .....	1.8
Optional Accessories .....	1.9
Remote alarm .....	1.9.1
<b>SETUP</b> .....	<b>2.0</b>
Assembling the Monitor .....	2.1
Mounting the Monitor .....	2.2
Compressed-Air Connections .....	2.3
Air pressure requirements .....	2.3.1
Connecting to respirator air supply .....	2.3.2
Electrical Connections .....	2.4
120-volt AC supply .....	2.4.1
220-volt AC 50/60-Hz supply .....	2.4.2
AC to 12-volt DC field conversion .....	2.4.3
Changing Alarm Trip Point .....	2.5
Connecting an External Alarm and Shutdown device ...	2.6
Changing Mode Select Dip Switch to Delay Alarm ....	2.7
<b>OPERATION</b> .....	<b>3.0</b>
Setup for Operation .....	3.1
Warm-Up Period .....	3.2
Operating Mode .....	3.3
Shutdown .....	3.4
<b>CALIBRATION TEST AND CALIBRATION</b> .....	<b>4.0</b>
Difference Between Calibration Test and Calibration ...	4.1
Calibration test .....	4.1.2
Calibration process .....	4.1.3
Materials Required for Tests and Calibration .....	4.2
Stabilization Period .....	4.3
Prepare Calibration Connector .....	4.4
Prepare Monitor for Calibration .....	4.5
Calibration Test .....	4.6
Calibration .....	4.7
Return Monitor to Operating Mode .....	4.8
Impurity-Free Air (zero contamination) Test .....	4.9
<b>SETTING ZERO BASELINE</b> .....	<b>5.0</b>

**GENERAL MAINTENANCE .....6.0**  
 Cleaning .....6.1  
 Calibration Test Schedule .....6.2  
 Calibration Schedule .....6.3  
 Alarm Test .....6.4

**SERVICE MAINTENANCE .....7.0**  
 Sensor Replacement .....7.1  
 Fuse Replacement .....7.2

**TROUBLESHOOTING .....8.0**  
 Instrument Will Not Calibrate .....8.1  
 Intermittent Alarm .....8.2  
 No Annunciator Lights or Alarms .....8.3  
 Alarm Lights or Alarm Horn Fails .....8.4

**ACCESSORIES AND REPLACEMENT PARTS .....9.0**

**1.4 Components**

**1.4.1** The primary components are shown in Figure 1. The instrumentation is enclosed in a nonmetallic case. The monitor system includes the instrument case,

filter/regulator, 10 feet of 1/8" ID x 1/4" OD tubing with adaptor fittings, a cylinder of 10 ppm (parts per million) test gas, and calibration connector that includes the connector valve and tubing.

**1.5 Operating Principles**

**1.5.1** The CMS monitor samples respiratory air from a breathing-air source. The air to the respirator does not actually pass through the monitor. This enables one monitor to detect CO (carbon monoxide) in the entire breathing-air system, not just the air to a single respirator.

**⚠ WARNING**

**When the CMS is correctly installed and maintained, it monitors the level of CO in the air supply. The instrument is a monitoring device; it DOES NOT remove or convert CO.**

**Figure 1**

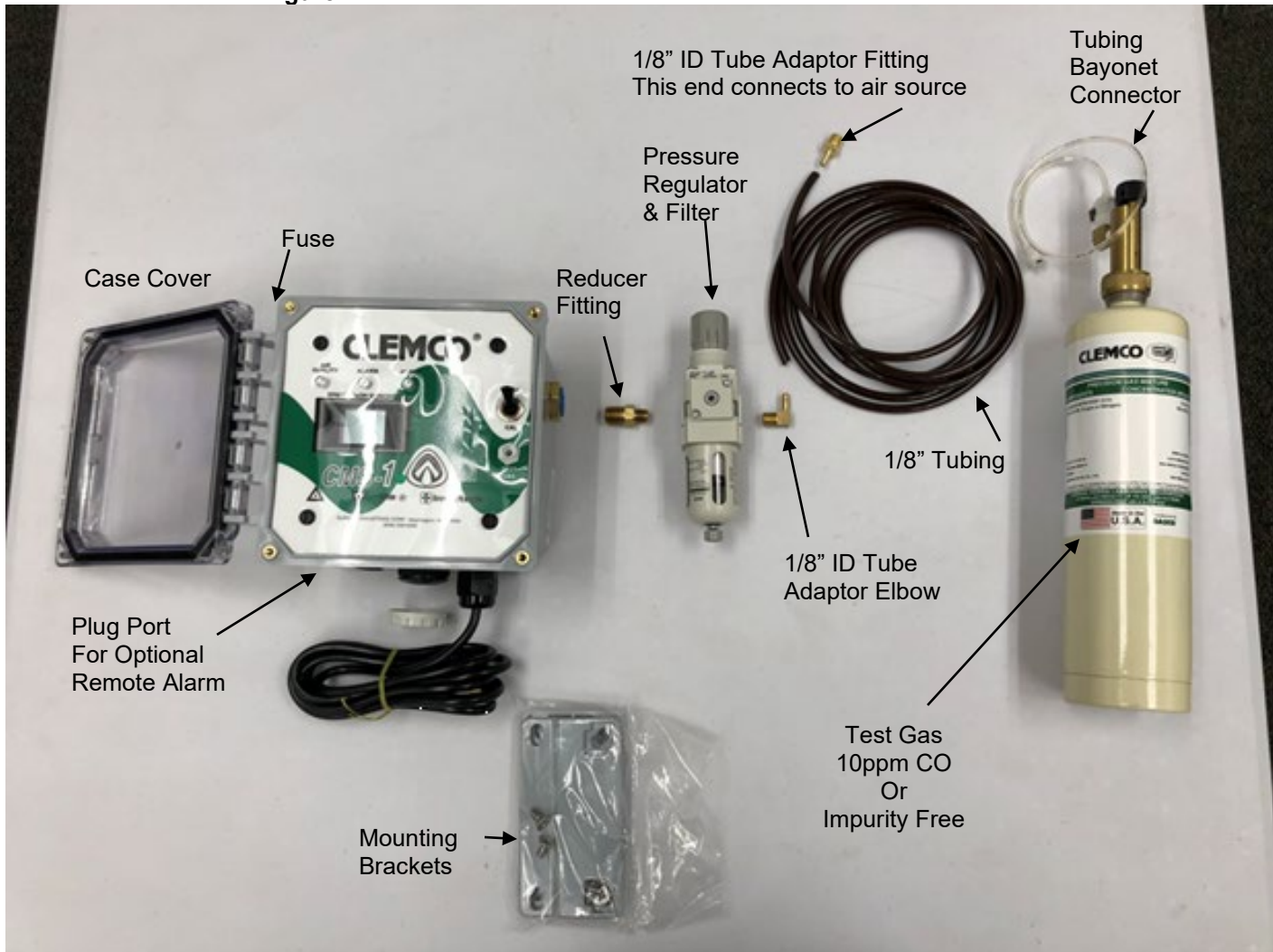

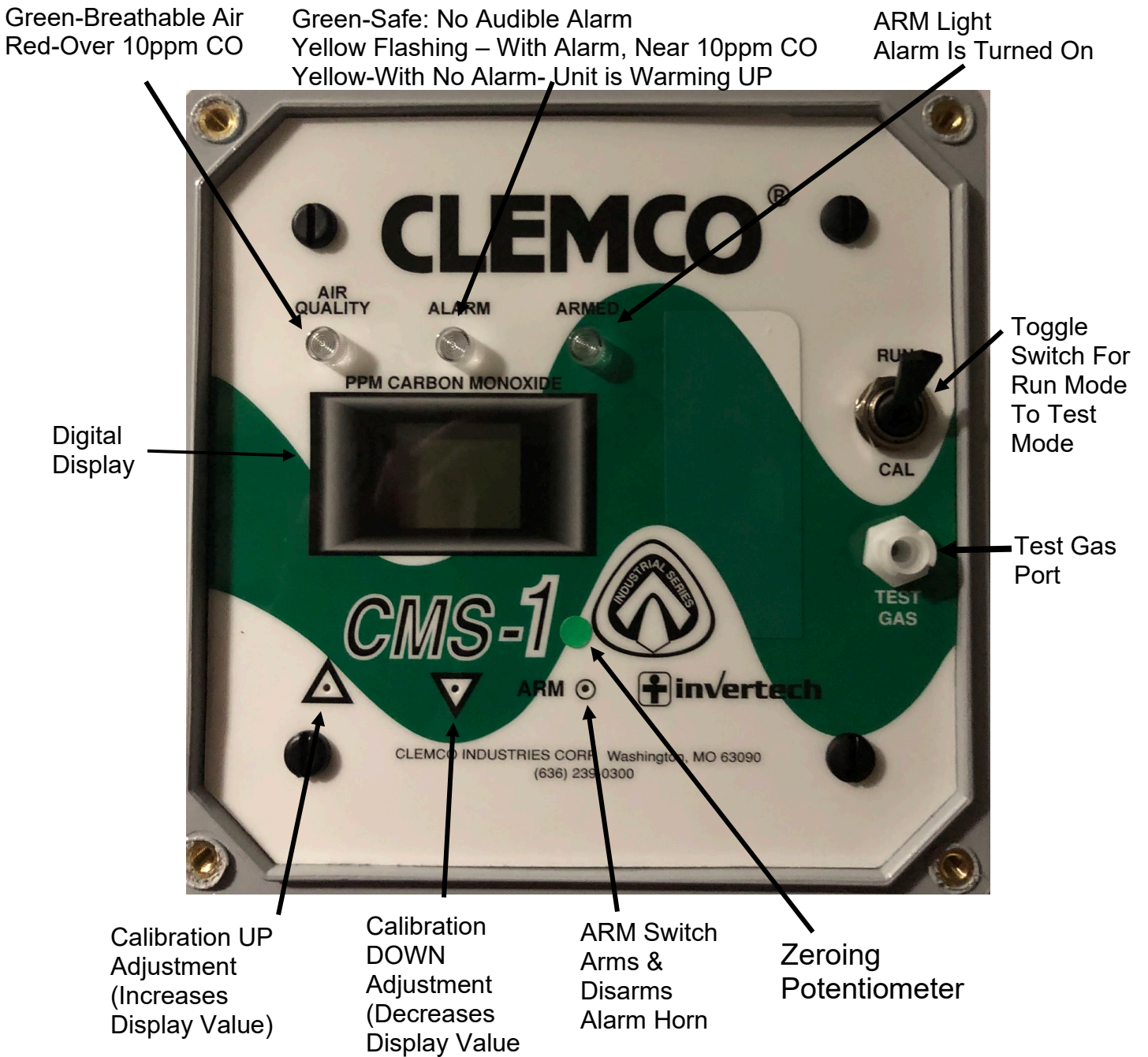

Use The Triangular Adjustment Ports To Calibrate The Monitor Using Only 10ppm Test Gas

**1.5.2** During operation, a small sample of air, referred to as sample air, passes through the instrument, and is continuously monitored by the chemical cell sensor. If the sample-air supply fails for any reason, such as air blockage, loss of pressure, or excessively high pressure, an intermittent alarm horn will sound approximately every 10 seconds and the alarm light will illuminate *yellow* to alert the user.

**1.5.3** The alarm trip point is preset at 10 parts per million (ppm), which is the maximum permissible exposure level (PEL) of CO for Grade-D breathing air in the USA. Refer to Section 2.5 to change the alarm trip point to 5 ppm when required by local regulations.

**1.5.4** In the event CO is detected in concentrations of 10 ppm, a continuous alarm horn sounds and the AIR QUALITY alarm light illuminates *red*. The alarms alert the user to immediately stop blasting and remove the respirator as soon as it is safe to do so.

## 1.6 Annunciator Lights and Audible Alarm Use and Functions

**1.6.1** A horn (audible alarm) is provided on the exterior of the instrument case, and annunciator lights (visual alarms) are mounted on the faceplate. The lights illuminate *green* when conditions are safe, or *yellow* or *red* when an alarm occurs. The alarm horn sounds in conjunction with the visual alarm.

### WARNING

**All alarm conditions require the immediate attention of the user. Stop blasting immediately and remove the respirator as soon as it is safe to do. Check the monitor to determine the cause for alarm.**

**1.6.2** The alarm lights and the nature of the alarm horn indicate the condition causing an alarm. Functions of the alarm annunciators are as follows:

**Armed Light:** This indicates whether the alarm horn is armed. *Green* means the alarm horn is armed; no light means it is disarmed. **NOTE: The horn should be disarmed only to temporarily silence it during calibration by the technician.**

### WARNING

**Do not use the compressed air monitored by this instrument for breathing without checking to make sure all three alarm lights are illuminated *green*. Failure to heed this warning can cause death from the inhalation of CO.**

## Alarm Light:

### Green Light - No Audible Horn

Indicates there is correct air flow and pressure to the sensor. Correct flow is observed on the flow meter; the flow ball should be between 0.5 and 0.8 SCFH (standard cubic feet per hour).

### Yellow Light - Intermittent Alarm Horn (approximately every 10 seconds)

**Sample-Air Failure:** This alarm is due to either low flow, or high flow in the test chamber. Low flow (flow ball is low in the flow meter) is usually due to loss of pressure or plug in the sample-air line, or the external pressure regulator is set too low. High flow (flow ball is high in the flow meter) is an indication that the external pressure regulator is set too high.

### Yellow Light - No Audible Horn

**Warm-Up Period:** During the first minute or two of operation, the monitor goes through a warm-up period while the sensor stabilizes. During the warm-up period, this alarm occurs and all other alarms are non-operational. After the warm-up is complete, the alarm light turns *green* if the air is free of CO, or it turns *red* if the air is contaminated with CO.

## Air Quality light:

### Green Light - No Audible Horn

**Safe Condition:** This means the sample-air gas is below the permissible exposure level. **Do not use the compressed air for breathing unless the AIR QUALITY light is illuminated *green*.**

### Red Light - Continuous Audible Horn Alarm

**Toxic Gas Detected:** This alarm occurs when the sensor detects 10 ppm of CO.

**NOTE:** The alarm light may be *red* for a brief time as the sensor stabilizes after the warm-up.

## 1.7 Digital Display Window

**1.7.1** The digital display shows two readings, the level of carbon monoxide (CO) in parts per million (ppm), and if the airflow rate is too low to measure the CO levels.. The sensor also responds to hydrogen sulfide and a limited number of other toxic gases, and may display inflated CO readings when other toxic gases are detected.

**NOTE:** The display may be slightly high for a brief period while the sensor stabilizes after the warm-up.

## 1.8 Switches, Use and Functions

**1.8.1 Run/Calibration Switch:** Position the toggle in the RUN position during the operating mode (all

operations other than the actual calibration test and calibration process). If the toggle is not in the RUN position, the instrument will initiate a *yellow* light and intermittent alarm, indicating that the sample-air is not reaching the sensor. Correctly positioning the toggle will terminate the intermittent alarm.

**1.8.2 Arm/Disarm Switch:** This switch arms and disarms the alarm horn. The switch is tripped ON and OFF by inserting a small probe (a straightened paper clip works well) through the small access opening in the faceplate and pushing gently until the detent is felt. It may take a couple pushes to trip the switch. The horn is armed when the ARM light is *green*. The horn is disarmed when the light is unlit. **NOTE: The horn should be disarmed only to temporarily silence it during calibration by the technician.**

## 1.9 Optional Accessories

**1.9.1 Remote alarm:** The 12-volt DC remote alarm is a high-intensity, red-lens strobe light and high-decibel horn. Unlike external alarms, this alarm does not require an external power source. Installation instructions are provided with the alarm.

Its use is recommended in a high-noise area or where the monitor cannot be placed in a conspicuous location. The alarm kit includes the alarm, stand, wiring connector, and 50 foot cable. See Accessories in Section 9.1. With additional cable, the remote alarm may be placed up to 150 feet from monitor.

## 2.0 SETUP

### 2.1 Assembling the Monitor – Figure 2

**2.1.1** Using the screws and instructions provided in the mounting flange packet, attach the mounting flanges to the instrument case.

**2.1.2** Apply Teflon thread seal tape to the male threads of the 1/4" x 1/8" reducer fitting and tubing elbow, and assemble as shown in Figure 2. Make sure the regulator is correctly installed so the air flows toward the instrument. The tubing elbow may be rotated after the instrument is mounted to enable the tubing to be connected with minimum bends.

### 2.2 Mounting the Monitor

**2.2.1** The simplest way to mount the CMS-1 is with the mounting flanges provided, as shown in Figure 2. Mount the monitor in convenient location that is close to the compressed air source. Refer to Section 2.3.2. The

monitor must be positioned upright and level to ensure the flow meter responds correctly. Place the monitor on a wall or panel, and mark the mounting hole locations. Drill appropriately sized holes and secure with fasteners.

## **⚠ WARNING**

**DO NOT mount this instrument inside a blast room. An operator wearing protective clothing inside a blast room will not hear the alarm horn when the instrument is in an alarm condition. The alarm case is not designed to withstand the continual impact of abrasive that takes place inside a blast room. DO NOT mount this instrument inside a paint room or in an explosive or flammable environment. This instrument is not rated for explosive atmospheres.**

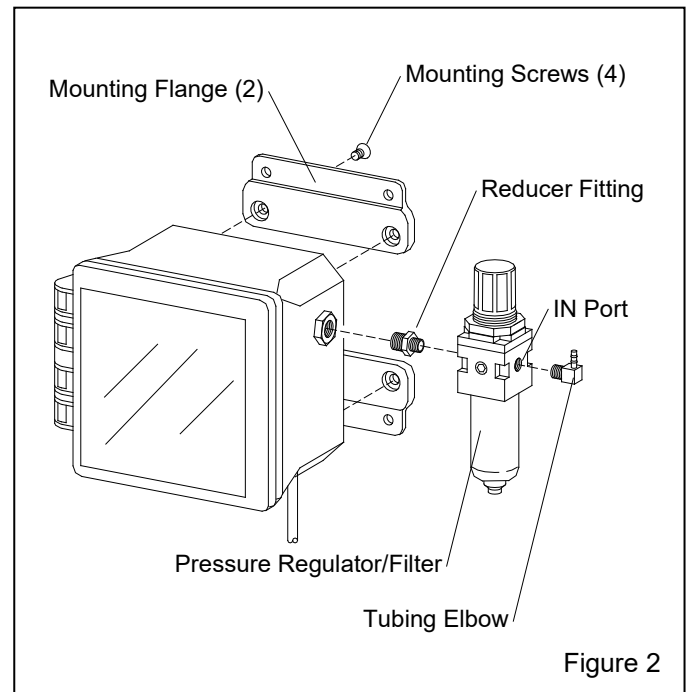

## 2.3 Compressed Air Connections

### 2.3.1 Air pressure requirements

**2.3.1.1** If the compressed air source pressure is between 55 psi and 145 psi, no line pressure adjustment is required. If line pressure is above 145 psi, a regulator is required in the air line (before the monitor's regulator) to reduce pressure to be within the 55 psi to 145 psi operating range. Pressure above 145 psi could damage the monitor.

### 2.3.2 Connecting to respirator air supply

## NOTICE

**Do not use pipe joint compound to seal pipe fittings. Use Teflon tape for pipe-thread sealer. Although unlikely, there is a possibility the monitor will respond to gases given off by some compounds.**

**2.3.2.1** To ensure accurate and rapid air monitoring, the instrument must be placed as close to the compressed air source as practical. Ten feet of 1/8" ID tubing with one 1/8" NPT elbow/tubing adaptor and one 1/8" NPT straight adaptor are furnished to be used between the compressed air source and monitor inlet. Do not use larger diameter tubing or pipe, or longer lengths of tubing, as it increases the time it takes for the sample air to reach the monitor.

**2.3.2.2** Locate a suitable place to tap into the respirator compressed air supply. Do not tap into a dead-end air line. The tap location must be where moving air is assured. The tap location should be within 10 feet of the monitor, and the monitor must be placed in a location that permits continual observance of the visual and audible alarms.

## WARNING

**The monitor, remote alarm, or an auxiliary external alarm, must be in a conspicuous place to ensure that any alarm condition is observed. Using the dry-contact terminals and a relay, the monitor may be interlocked with other devices such as lights horns or compressor shutdown device to provide additional safeguard against an unobserved alarm.**

**2.3.2.3** Place a tee in the air-supply line, and use a bushing or other adaptor to connect the 1/8" NPT tube adaptor supplied. Install an isolation valve at the source to enable depressurization for service and to remove the monitor. Typical setups are shown in Figure 3.

**2.3.2.4** The air-supply-line tee should face upward to prevent water from accumulating in the sample-air line. If the tap cannot face upward, install a short 1/4" NPT drop pipe and drain to prevent water from entering the monitor.

**2.3.2.5** Attach the urethane tubing between the air-supply tube-adaptor fitting and monitor inlet-tube adaptor fitting. Cut off excess tubing.

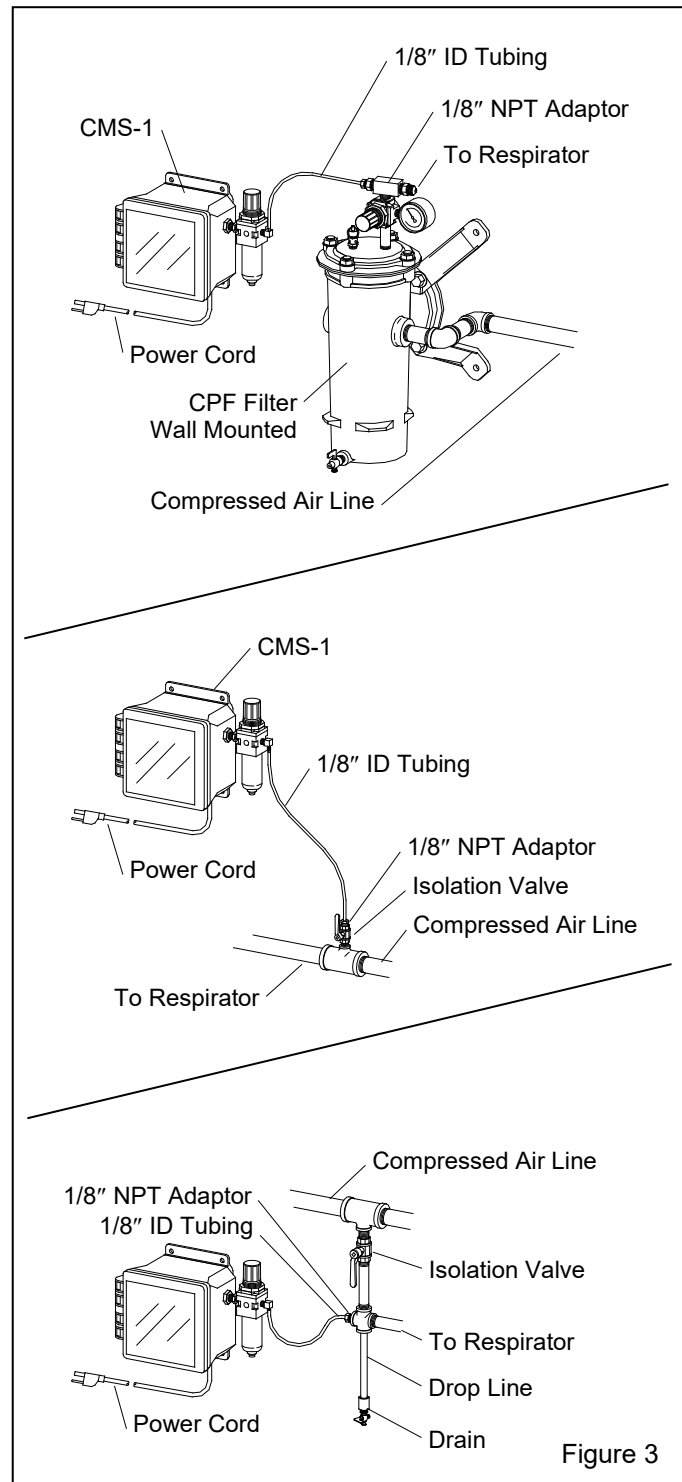

Figure 3

## 2.4 Electrical Connections

**2.4.1 120-volt AC supply:** CMS-1 monitors are generally installed indoors and operate on AC power. A 120-volt AC power cord is supplied and can be plugged into a compatible AC grounded electrical service. Electrical power may be rewired by a qualified electrician with conduit that conforms to applicable codes.

**2.4.2 220-volt AC, 50/60-Hz supply:** The only difference between the 120-volt and 220-volt monitor is the power cord. Remove the 120-volt cord or plug and replace it with one that is compatible with the grounded 220-volt receptacle.

**2.4.3 AC to 12-volt DC field conversion**

Note: The following field conversion instructions to 12-volt DC is for monitors with Serial No. 4446 and higher. To convert monitors with serial numbers lower than 4446, request manual No. 23301, Revision D or earlier.

The AC power cord provided with the monitor may be used, using *black* as the positive. A user supplied DC, 2-wire cord may be used, using red as positive. If a new 12-volt cord is used, splice the positive through the fuse and use the spade on the outlet of the fuse to connect to J5 DC positive post, as shown Figure 4.

**2.4.3.1** Make sure that all electrical power to the monitor is locked-out and tagged-out.

**2.4.3.2** Loosen the two case-cover screws and open the case cover.

**2.4.3.3** Remove the four faceplate screws and carefully remove the faceplate, being careful not to disconnect any wires or tubing. The screws on the hinged side of the plate are longer than those on the opposite side; replace accordingly.

**2.4.3.4** Remove the connector with *red* and *black* wires from the plug on the circuit board, as shown in Figure 4. If there is a chance the monitor will be converted back to AC power, tie the wires out of the way. If the monitor is to be permanently converted to 12 volts, pop off the clear terminal cover and remove the wires from the terminal.

**2.4.3.5** Disconnect the *white* and *black* wires from the power-supply lead wires at the connectors, as shown in Figure 4.

**2.4.3.6** Plug the *black* wire onto the J5 (DC +) post at the upper edge of the circuit board, as shown in Figure 4. Plug the *white* wire onto the J6 (DC-) post.

**2.4.3.7** Reposition the faceplate, making sure that all internal air lines are free of interference, binding, or kinks, and that all tube connections are secure. Tighten the faceplate screws finger-tight to ensure they are threading correctly, and then tighten to barely snug with a screwdriver.

**2.4.3.8** Close and secure the instrument case cover, tightening the screws to a maximum of 20-inch lbs.

**2.4.3.9** Remove the plug from the other end of the cord.

**2.4.3.10** Attach a positive (+) terminal connector to the end of the *black* wire and a negative (-) connector to the end of the *white* wire. Clip the *green* wire.

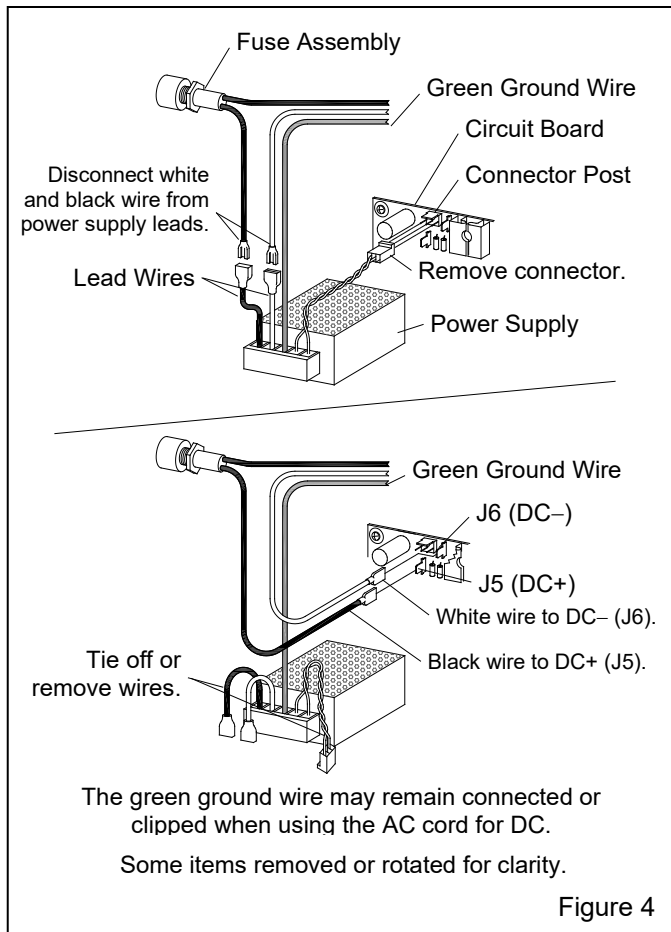

Figure 4

**NOTICE**

**Use any connectors that are compatible with a 12-volt DC system. Make sure the connectors are clearly marked positive (+) and negative (-). Attach the positive connector to the wire leading to the DC+ post on the circuit board and attach the negative connector to the DC- post on the circuit board. The monitor will not operate if wires are reversed.**

**2.5 Changing Alarm Trip Point**

**2.5.1** The alarm trip point is preset at 10 ppm, which is the maximum permissible exposure limit (PEL) of CO for Grade-D breathing air in the USA. Use the following instructions to change the trip point to 5 ppm when required by local regulations.

**2.5.2** Unplug the monitor from the power supply.



**2.5.3** Open the case cover and insert a straightened paper clip into the ARM port in the faceplate. While maintaining pressure on the paper clip, plug the monitor into the power supply; do not remove the paper clip.

**2.5.4** Observe the display window. It will show four lines of information; the bottom line is the trip-point (PPM 10). Within a few seconds the trip-point will change to PPM 5; when it changes, remove the paper clip. The trip point is now set to alarm at 5 ppm CO. Close cover.

**2.5.5** To change the trip point back to 10 ppm, unplug the monitor and repeat the process. There are only two settings: 10 ppm and 5 ppm.

**2.6 Connecting an External Alarm and Shutdown Device – Figure 5**

Note: External alarms require external power. Do not confuse an external alarm with the optional remote alarm, which does not require external power. Instructions for the remote alarm are provided with the alarm.

**2.6.1** A dry relay contact, rated at 5 amperes, is mounted on the circuit board as shown in Figure 5. An electrician will use the contacts to operate relays for external alarms and shutdown devices.

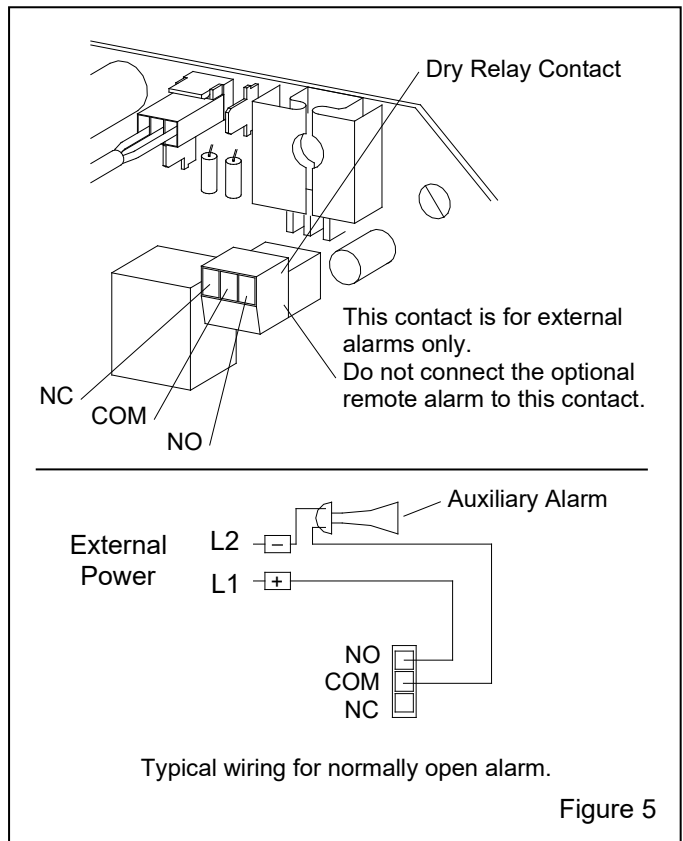

Figure 5

**2.7 Changing Mode Select Dip Switch to Delay Alarm – Figure 6**

**NOTE:** In areas where intermittent radio frequency transmissions cause false alarms, the monitor can be set to have a 10 second alarm delay to avoid false alarm conditions. The dip switch is mounted on the circuit board as shown in Figure 6.

**⚠ WARNING**

**Do not change the switch positions unless there are frequent alarms from radio frequency (RF) transmissions. Do not change the switch positions to any position other than noted in Figure 6. Avoid unnecessary tampering with the circuit board; doing so can change the monitor’s settings, which can affect CO alarm conditions.**

**2.7.1** The default and recommended setting has no delay in alarm-response time. The positions of the white mode-select switches are shown on the upper example in Figure 6 and as follows:

- Switch #1 .....Off
- Switch #2 .....On
- Switch #3 .....Off

**2.7.2** To delay the alarm by 10 seconds, set the white mode-select switches as shown on the lower example in Figure 6 and as follows:

- Switch #1 .....Off
- Switch #2 .....Off
- Switch #3 .....Off

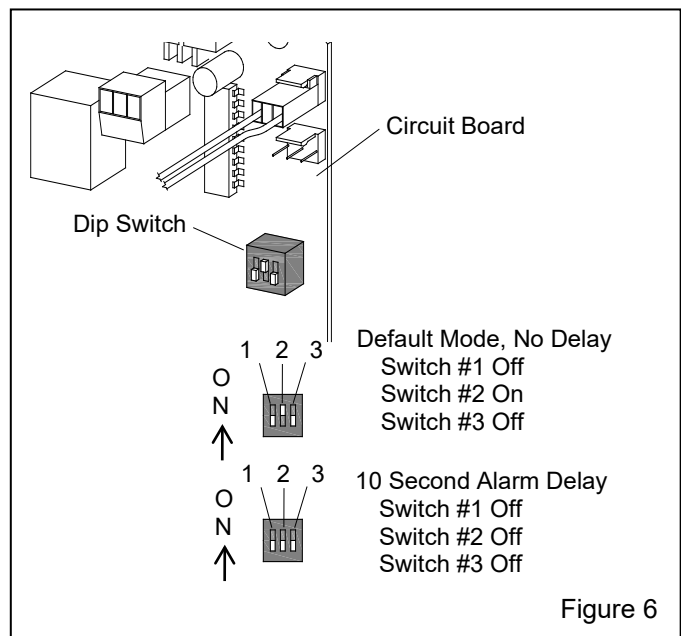

Figure 6

---

### 3.0 OPERATION

---

## WARNING

---

**Do not breathe compressed air that this instrument monitors unless the instrument has been calibration tested and, if needed, calibrated per Section 4.0. Using a monitor that has not been calibration tested can permit undetected CO to enter the respirator air lines. Breathing toxic gases can cause death.**

---

#### 3.1 Setup for Operation

**3.1.1** Position the Run/Calibration toggle switch to the RUN position.

**3.1.2** Open the sample-air isolation valve to supply air to the monitor.

**3.1.3** The digital display will show the status of the flow when an issue is detected. I will alarm with "Low Flow Alarm" on the readout screen

**3.1.4** Plug the instrument into a grounded 120-volt AC power supply. If the monitor was converted to operate on 12 volt, connect to a 12-volt DC power source. Make sure the positive and negative leads go to the correct terminal as noted in Paragraph 2.4.3.10 and the Notice following it. There is no ON/OFF switch on the monitor; it will begin operation as soon as power is applied.

#### 3.2 Warm-Up Period

**3.2.1** During the warm-up period adjust the airflow to assure the digital display does not alarm and show "Low Flow Alarm."

**3.2.2** During the warm-up period, the alarm horn is disabled and the ALARM light is *yellow*.

**3.2.3** At the end of the warm-up period, the alarm horn is reactivated and all the annunciator lights will be *green* indicating the following:

- ARMED: The alarm horn is armed to provide an audible alarm if CO reaches the permissible limit of 10 ppm.
- ALARM: There is correct sample-air flow to the sensor.
- AIR QUALITY: The sample air at the sensor does not exceed the permissible contamination limit.

**3.2.4** Make sure alarms function per Section 6.4. If the alarms function as described, proceed to place the instrument in operating mode, per Section 3.3.

**3.2.5** If the instrument goes into any alarm mode (any annunciator light is any color other than *green* or any audible alarm) after the warm-up, reinitiate the warm-up by terminating and restarting power. If the ARMED light is not lit or the ALARM light is *yellow* with an intermittent horn, proceed as follows:

ARMED light is not lit: The alarm may be disarmed. Arm the alarm by inserting a probe (straightened paper clip) through the small ARM access opening in the faceplate, pushing gently until the detent is felt. It may take several pushes to trip the switch.

ALARM light is *yellow* with an intermittent horn: This usually means low or high flow through the sensor. Generally, with the correct flow the ball will be between 0.4 and 0.9: in some cases slightly higher or lower flow is required. Increase or decrease pressure at the pressure regulator in half-turn increments until the horn silences. Approximately one minute later, the ALARM light should change from *yellow* to *green*.

**3.2.6** A continuous alarm with *red* AIR QUALITY light indicates that the sample air reaches the permissible exposure level (the digital display confirms the contamination level), or the instrument requires a calibration test. Refer to Section 4.0.

---

## WARNING

---

**DO NOT use the respirator during the warm-up period. Alarms are disabled during the warm-up and do not warn against toxic gases.**

---

#### 3.3 Operating Mode

**3.3.1** Following the warm-up period, with the toggle positioned to RUN, and the sample air flowing through the unit, the monitor is in full operating mode.

**3.3.2** Before donning the respirator, make sure the monitor is in the operating mode; all three alarm-lights must be lit *green*, with no audible alarm.

---

## WARNING

---

**Do not use compressed air monitored by this instrument for breathing without first checking that the instrument is in full operating mode and that all the annunciator lights are illuminated *green*. Failure to heed this warning can cause death from the inhalation of CO.**

---

**3.4 Shutdown**

**3.4.1** If the instrument is in a facility that has 24-hour compressed air and electrical power, there is no need to shut off the monitor. If the compressed air system is shutdown, the electrical power must also be turned off by unplugging the power cord or disengaging power if the monitor is permanently wired.

**NOTICE**

**If the compressed air source is shut down without shutting off electrical power, the monitor will go into low-flow alarm, sounding an intermittent alarm and displaying a yellow ALARM light.**

**4.0 CALIBRATION TEST AND CALIBRATION**

**NOTE:** Thoroughly review and understand the calibration test and calibration process before testing or calibrating the instrument. Refer to Section 4.1.

**WARNING**

The following calibration instructions are written for 10 ppm of CO Test Gas. To avoid confusion, do not test or calibrate the instrument with any concentration of CO test gas. Using other concentrations while following the calibrating instructions will place the monitor out of calibration and may fail to alert the user of toxic gases. Breathing toxic gases can cause death.

**4.1 Difference Between Calibration Test and the Calibration Process**

**4.1.1** It is important to understand the difference between calibration testing and the calibration process.

**4.1.2 Calibration test:** Calibration test means applying 10 ppm test gas to make sure the instrument responds with an alarm when CO concentration reaches the maximum permissible exposure level and that it responds with a safe signal when impurity-free air is applied. Calibration test does not include any adjustment of the instrument. Calibration (adjustments) should be done only when the calibration test shows it is necessary.

**4.1.3 Calibration process:** Calibration means adjusting the instrument. Calibration should be done only when the instrument does not respond during calibration testing or when it remains in alarm at startup.

**4.2 Materials Required for Tests and Calibration**

- 10 ppm test gas ..... Stock No. 22865
- Impurity-free test gas (when required; refer to Section 4.9) ..... Stock No. 11132
- Calibration connector ..... Stock No. 23011
- Straightened paper clip (when calibration is required)

**4.3 Stabilization Period**

**4.3.1** The monitor must be in operation for at least 30 minutes before calibration tests. DO NOT test the instrument until it has gone through the warm-up period and has been in operation with sample air flowing through it (see Section 3.0) for at least 30 minutes.

**4.4 Prepare Calibration Connector – Figure 7**

**4.4.1** Insert the tubing connector into the slide release until it snaps into position. Gently pull the connector to make sure it is seated and locked.

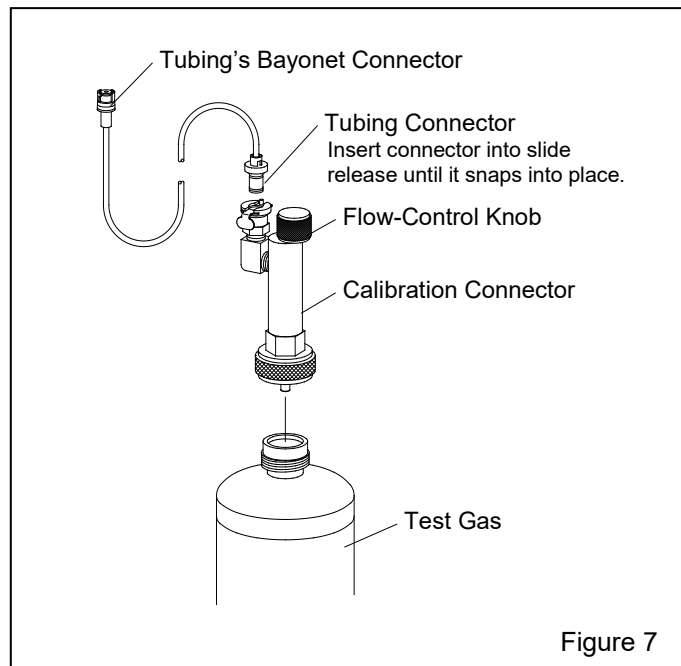

Figure 7

**4.4.2** Make sure the flow-control knob is turned fully clockwise to the CLOSED position.

**4.4.3** Thread the calibration connector onto the cylinder of test gas.

**4.5 Prepare Monitor for Calibration**

**4.5.1** Open the instrument case cover to access the faceplate. Refer to Figure 9 for faceplate-calibration and testing callouts.

**4.5.2** Connect the tubing's bayonet connector to the "Test Gas" port by aligning the tabs, insert the connector into the port, and turn it slightly clockwise until it locks.

**4.6 Calibration Test**

**4.6.1** Connect the calibration connector and test gas per Sections 4.4 and 4.5.

**4.6.2** Place the Run/Calibration toggle toward CAL (calibration). The ALARM light will immediately turn *yellow*, and within a few seconds the intermittent alarm horn will sound. Disarming the alarm per Section 1.8.2 will silence the horn during calibration tests.

**4.6.3** Refer to Figure 8 and slowly open the flow-control knob on the calibration connector to introduce test gas. Test gas is entering the unit when the flow meter ball rises. If the ball does not rise when the calibration valve is opened, the test gas cylinder may be empty.

**4.6.4** Adjust the flow-control knob until the flow meter ball remains between .5 and .8 SCFH, normally a little nearer to .8. The valve is extremely sensitive; several minor adjustments may be required to correctly position the ball.

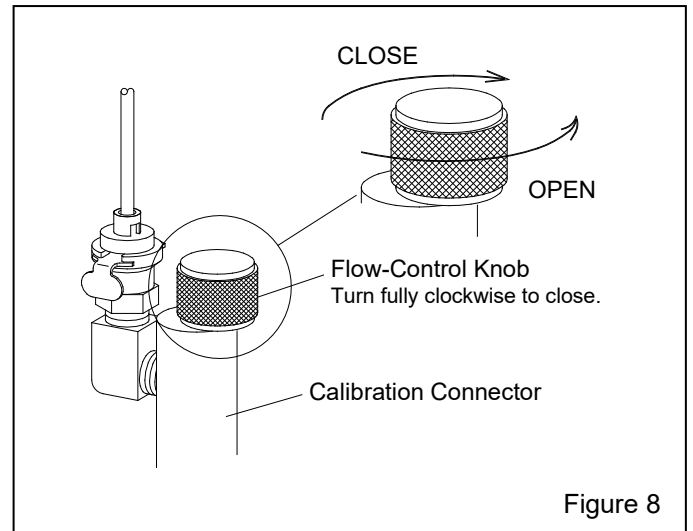

Figure 8

**4.6.5** Allow test gas to flow through the instrument until the digital readout stabilizes (about one minute).

**4.6.6** If the display stabilizes between 9 ppm and 11 ppm (10 ppm plus or minus one), the calibration test is complete. Return to operating mode per Section 4.8.

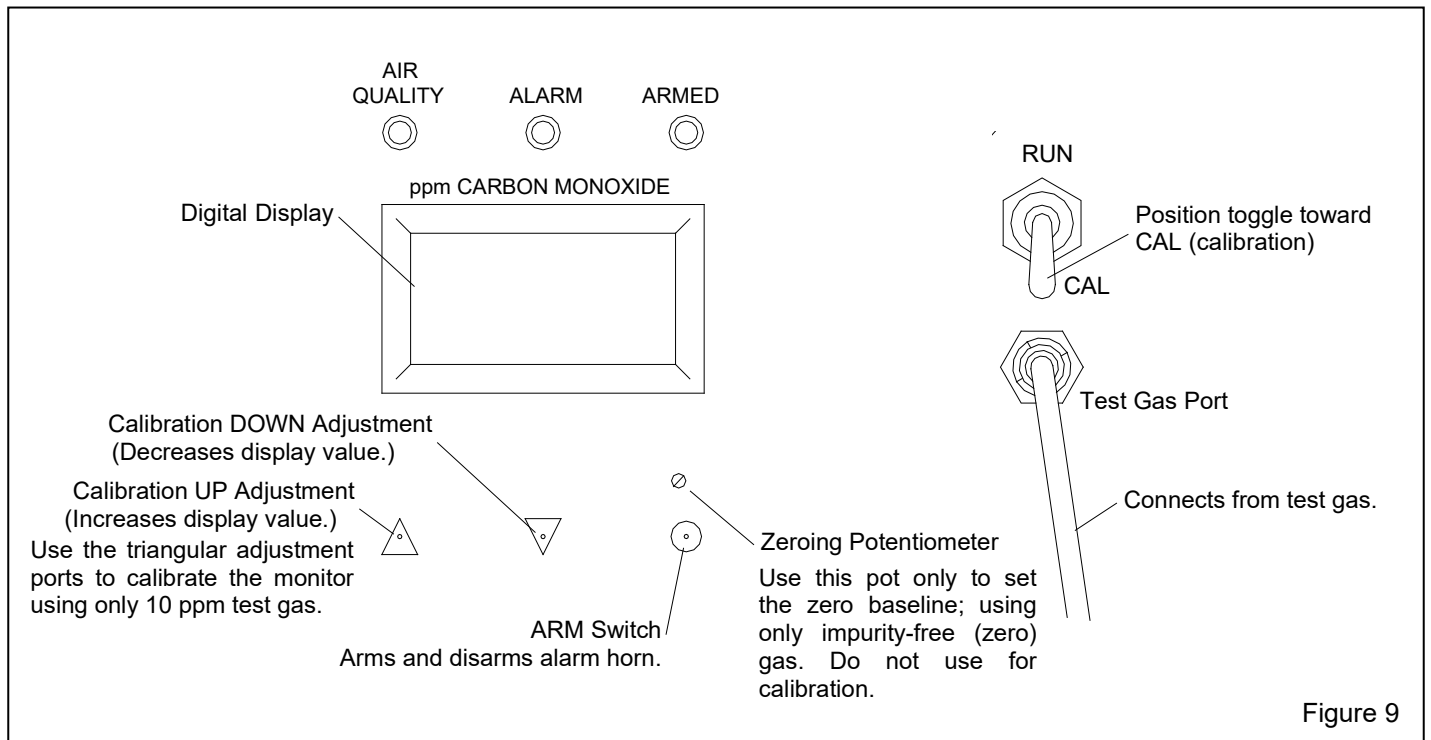

Figure 9

**4.6.7** If the display stabilizes at any value other than between 9 ppm to 11 ppm and if the instrument has been in operation for at least 30 minutes, calibrate the instrument per Section 4.7. If the instrument has not been in operation for 30 minutes, return it to operating mode per Section 4.8 and operate with sample air for at least 30 additional minutes. Retest the calibration. If the display stabilizes at a value other than 10 ppm plus or minus one, calibrate the instrument per Section 4.7.

**4.6.8** When test/calibration is completed, return the instrument to operating mode per Section 4.8.

## 4.7 Calibration

**4.7.1** Do not calibrate the instrument unless it has gone through two stabilizing periods and calibration tests, per Sections 4.3 and 4.6, and only if the digital display is other than 09, 10, or 11 (10 ppm plus or minus one).

**4.7.2** Connect the calibration connector and 10 ppm test gas per Sections 4.4 and 4.5.

**4.7.3** Place the Run/Calibration toggle toward CALIBRATION. Slowly open the air flow knob until there is no alarm and the digital readout does not say "Low Flow Alarm"

**4.7.4** Allow test gas to flow through the instrument for about one minute.

**4.7.5** If the number in the display is lower than 9 ppm, calibrate through the upright triangle. If the number is higher than 11 ppm, calibrate through the inverted triangle. Calibrate by inserting a straightened paper clip through the small access opening in the appropriate triangle, pushing gently until the detent is felt. It takes several gentle pushes to change the display. Repeatedly and slowly, press the switch until the display registers 10 ppm.

**4.7.6** When the display shows 10 ppm, the monitor is calibrated. Return the instrument to operating mode per Section 4.8.

## 4.8 Return Monitor to Operating Mode

**4.8.1** Turn the flow-control knob counterclockwise to close the calibration-connector valve.

**4.8.2** Remove the calibration tubing from the monitor by gripping the tube-end connector, push in lightly, turn it counterclockwise to unlock, and pull straight out.

**4.8.3** Place the Run/Calibration toggle switch toward RUN. The digital display should not have, "Low Flow

Alarm". After the warm-up, the ALARM light should change from *yellow* to *green*. If the light does not change to *green*, increase or decrease flow by adjusting the pressure regulator as required.

**4.8.4** Make sure the ARM light is lit. Refer to Section 1.6.2.

**4.8.5** Close the instrument case cover and tighten the screws to a maximum of 20-inch lbs.

**4.8.6** Remove the calibration connector from the test gas. The test gas cylinder has a positive seal, whereas the calibration connector valve does not. **NOTE: If the connector is not removed from the test gas cylinder, over time the cylinder will empty.**

**4.8.7** If the tubing needs to be removed from the calibration connector, press and hold the slide-release fitting and gently pull the tubing connector from the fitting.

**4.8.8** Store all material in a clean dry area.

## 4.9 Impurity-Free Air (zero contamination) Test

**4.9.1** This test should be done whenever the instrument stays in an alarm condition after it is returned to the operating mode. This test shows whether the alarm is due to contaminated air or a malfunctioning monitor.

**4.9.2** Follow the steps in Section 4.6: Calibration Testing, except use impurity-free test gas in place of 10 ppm gas.

**4.9.3.** If the monitor is correctly calibrated and in working order, the display will show 00 ppm. This means the monitor was accurately reading contaminated air. **NOTE: Do not use the compressed air for breathing until the display reads a safe level, below 10 ppm.**

---

## WARNING

---

**Do not breathe air that this instrument identifies as toxic until the source of contamination is identified and corrected. Breathing toxic gases can cause death.**

---

**4.9.4** Identify the source of contamination. Do not overlook the possibility that contaminated air entered the compressor intake. The contamination could be from engine or other exhaust entering the intake. If the source of contamination is temporary, the monitor will return to a

non-alarm (safe) condition after the contamination is cleared from the compressed air system.

**4.9.5** If the monitor is out of adjustment or not in good working order, the display will show other than 00 ppm. Check the zero baseline per Section 5.0.

**4.9.5.1** Calibrate the monitor per Section 4.7 and reapply impurity-free gas. If the display still shows other than 00 ppm, the monitor requires service.

## WARNING

**Do not use compressed air monitored by this instrument for breathing unless the instrument is in good working condition. Using a monitor that is not in calibration or not working correctly can permit undetected CO to enter the breathing-air lines. Breathing toxic gases can cause death.**

## 5.0 SETTING ZERO BASELINE

The following materials are required before zeroing the monitor:

- Impurity-Free Gas .....Stock No. 11132
- Calibration Connector .....Stock No. 23011
- Medium-size screwdriver
- Miniature screwdriver

**5.1** The monitor must be in operation for at least 30 minutes before zeroing. **NOTE: If zeroing follows sensor replacement, repeat the process after two days of operation.**

**5.2** Open the instrument case cover to access the faceplate. Refer to Figure 9 for callouts.

**5.3** Attach the calibration connector to the impurity-free gas, per Section 4.4.

**5.4** Connect the tube bayonet connector to the Test Gas port by aligning the tabs, insert the connector into the port, and turn it clockwise to lock. Gently pull the tubing to make sure it is locked in place.

**5.5** Place the Run/Calibration toggle toward CAL (calibration). The ALARM light will immediately turn *yellow*, and within a few seconds the intermittent alarm horn will sound. Disarming the alarm per Section 1.8.2 will silence the horn during the adjustment.

**5.6** Refer to Figure 8 and slowly open the calibration flow-control valve to introduce test gas. Test gas is entering the unit when the flow meter ball rises. If the ball does not rise when the calibration valve is opened, the test gas cylinder is probably empty.

**5.7** Adjust the flow-control knob until the digital display does not have "Low Flow Alarm." The valve is extremely sensitive; several minor adjustments may be required..

**5.8** Allow test gas to flow through the instrument until the digital readout stabilizes (about one minute).

**5.9** Using a miniature screwdriver inserted through the zeroing potentiometer opening, adjust the potentiometer until the display reads .00 (decimal, zero, zero) The readout responds slowly to the potentiometer adjustment. Turn it slowly when making adjustments.

**5.10** After the display shows .00, slowly turn the potentiometer clockwise until the decimal disappears.

**5.11** Return the instrument to operating mode per Section 4.8.

## 6.0 GENERAL MAINTENANCE

### 6.1 Cleaning

**6.1.1** The need to open the case periodically to calibrate the instrument subjects it to external contamination. Take care not to introduce contaminants into the instrument when the case is open.

**6.1.2** Clean the exterior of the case with a cloth soaked in a solution of water and mild detergent. Do not clean with solvent cleaners.

### 6.2 Calibration Test Schedule

**6.2.1** Test the calibration when it is initially set up and daily for the first week. Check it once a week for the first month. Check it at least once a month thereafter. Refer to Section 4.0 for test procedure.

### 6.3 Calibration Schedule

**6.3.1** Avoid the urge to calibrate the instrument. Calibrate only when the calibration tests show it is required. Refer to Section 4.0.

**6.4 Alarm Test**

**6.4.1** Although uncommon, alarm lights and horns do fail. Check their function before each use by placing the Run/Calibration toggle toward CAL. The ALARM light will immediately turn *yellow*, and within a few seconds the intermittent alarm horn will sound. Placing the toggle in RUN position returns the alarms to their normal operation. **Never use the respirator without first verifying that the monitor is in the operating mode; all three annunciator lights must be green, with no audible alarm.**

**7.0 SERVICE MAINTENANCE**

**NOTE: Do not attempt to repair the instrument or replace any item that is not listed in this section or that requires parts not shown in Section 9.0. Contact a Clemco distributor for authorization to return the instrument for evaluation or service.**

**7.1 Sensor Replacement**

**7.1.1** Sensor life depends on several factors, but in most cases the sensor should last two to three years. Signs that the sensor is failing is the frequent need to calibrate the monitor and large spans (drifting) in the display from one calibration to another.

**7.1.2** The following materials are required to replace the sensor:

- 10 ppm test gas ..... Stock No. 22865
- Impurity-free gas ..... Stock No. 11132
- Calibration connector ..... Stock No. 23011
- Sensor ..... Stock No. 23015
- Medium-size screwdriver
- Small screwdriver

**7.1.3** Open the instrument case and remove the four faceplate screws.

**NOTE:** The screws on the left are shorter than those on the right; replace accordingly.

**7.1.4** Carefully lift the faceplate to expose the instrumentation, using care not to disconnect any wires or tubing.

**7.1.5** Locate the clear-plastic sensor housing, shown in Figure 10, and remove the mounting screws. The screws are easily removed Do not press hard against the screw heads; **excessive pressure could damage the circuit board.**

**7.1.6** Carefully lift the sensor housing out of the way.

**7.1.7** Pull straight up to remove the sensor.

**7.1.8** Discard the old sensor to prevent reuse.

**7.1.9** Handle the new sensor with care. Remove the shorting spring from the pins, as shown in Figure 10, and then plug the sensor into the sockets.

**7.1.10** Place the sensor housing over the sensor. Align the mounting screw holes, and alternately tighten the screws until snug. **Do not push hard on the screw heads when tightening. Do not overtighten the screws; excessive pressure could damage the circuit board.**

**7.1.11** Replace the faceplate, making sure that all internal air lines are free of interference, binding or kinks, and that all tube connections and wire connections are secure. Tighten the faceplate screws finger-tight to ensure they are threading correctly and then tighten them barely snug with a screwdriver.

**7.1.12** Apply sample air and power per Section 3.0. Run the monitor in operating mode for at least four hours before calibrating.

**7.1.13** Check the display to verify it reads zero 00. If not, adjust per Section 5.0.

**7.1.14** Calibrate per Section 4.0.

**7.1.15** Close and secure the instrument case cover, tightening the screws to a maximum of 20-inch-lbs.

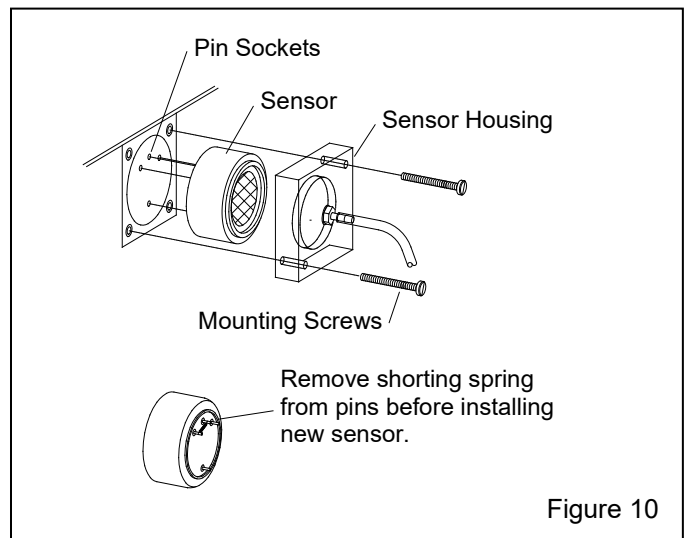

Figure 10

**7.1.16** Return the monitor to service and record sensor replacement date.

**7.1.17** Follow calibration test schedule per Section 6.2.

## 7.2 Fuse Replacement

**7.2.1** The fuse cap is located on the side of the instrument case. Remove the cap to access the fuse. Purchase a 1-amp fuse locally and keep spares on hand.

## 8.0 TROUBLESHOOTING

### WARNING

**Shorting electrical components can result in serious electrical shocks or can damage equipment. All electrical troubleshooting must be performed by a qualified electrician.**

**8.1 Instrument Will Not Calibrate:** If the display does not stabilize or respond to calibration adjustments.

**8.1.1** Make sure the Run/Calibration toggle switch is set toward CAL.

**8.1.2** Check flow meter. If the flow ball does not rise, the connector's slide valve may be off or calibration cylinder may be empty.

**8.1.3** Replace sensor.

**8.2 Intermittent Alarm:** A pressure switch monitors pressure of sample air delivered to the sensor. If pressure at the switch (which is monitored by flow through the flow meter) drops below minimum requirement or rises above maximum, the monitor initiates an intermittent alarm.

**8.2.1** Before doing pressure tests, make sure the Run/Calibration toggle switch is toward RUN. If the toggle is not in the RUN position, the instrument will initiate an intermittent alarm, indicating that the sample air is not reaching the sensor. Correctly positioning the toggle will terminate the intermittent alarm.

**8.2.2** Make sure the sample air is between 55 psi and 145 psi. If the sample air is higher than 55 psi, the restriction is internal. Proceed as follows:

**8.2.3** Check flow through the flow meter. If the digital display reads "Low Flow Alarm," adjust the pressure regulator accordingly until the "Low Flow Alarm" disappears. In some cases, slightly higher or lower flow is required. Slowly increase and decrease pressure at the pressure regulator. If the regulator pressure was set

outside the limits, the alarm will disengage as soon as the pressure is corrected.

**8.2.4** Check internal instrumentation tubing for breaks, kinks, or disconnection. If tubing has come loose, reconnecting it will re-establish function and the monitor should operate correctly.

**8.2.5** Inspect purple restrictor orifice for blockage; orifice is extremely small (.004"). Replace the orifice if it is blocked.

### NOTICE

**Tubing coming loose can be the result of supplying the instrument with pressure much higher than operating pressure. Refer to Section 2.3.1. If this type of failure occurs, the maintenance service technician should inspect the instrument as soon as possible.**

**8.3 No Annunciator Lights or Alarms:** This condition indicates a loss of electrical power, as it is unlikely that audible and visual alarms will fail at the same time.

**8.3.1** Make sure the electrical power cord is connected to the appropriate power source.

**8.3.2** Make sure the fuse, located in the case, is not blown.

**8.3.3** Make sure that the power supply is ON.

**8.3.4** For 12-volt system, make sure the battery is fully charged and that the charging system is operational. Make sure the positive and negative terminals are connected correctly.

**8.3.5** Check for faulty power supply or loose plug connection on circuit board.

**8.4 Alarm Lights or Alarm Horn Fails**

**8.4.1** Check for loose plug connections on circuit board.

**8.4.2** To test the alarm, remove the plug connection on the circuit board from the suspect alarm and apply external 12-volt power to the alarm plug. If the alarm fails to activate, replace the alarm.

**8.4.3** To test the circuit board, remove the plug connection from the faulty alarm. Use a voltmeter to check voltage across circuit board pins. When testing an



alarm horn, switch the Run/Calibration Switch to the CAL (calibration) position. This will cause an intermittent alarm and should register on the voltmeter each time the alarm activates. A monitor with faulty circuit board should be returned for service.

**9.0 ACCESSORIES AND REPLACEMENT PARTS**

**9.1 Accessories**

Description	Stock No.
(-) Remote alarm kit, includes: alarm, stand, wiring connector and 50-ft. cable	22909
(-) Cable, 50 feet remote alarm extension	22910

**9.2 Replacement Parts – Figure 11**

Item	Description	Stock No.
(-)	CMS-1, 120-volt monitor package, includes: CO monitor, calibration connector and 10 ppm test gas	23017

- (-) CMS-1, 120-volt monitor only, includes: CO monitor and items 3 through 9 .....23012
- 1. Calibration connector assembly includes tubing and bayonet connector....23011
- 2. Test gas
  - 10 ppm .....22865
  - Impurity free .....11132
- 3. Regulator/filter, 1/8-NPT .....23013
- 4. Flow meter .....21376
- 5. Horn w/wire and connector, 12-volt DC ....22922
- 6. Adaptor, straight, 1/8" NPT x 1/8" barb .....11732
- 7. Adaptor, elbow, 1/8" NPT x 1/8" barb .....11733
- 8. Tubing, 1/8" urethane, per foot .....12475
- 9. Reducer nipple, 1/4" x 1/8" .....02026
- 10. Tubing, for item 1, also used internally per ft., specify length required .....29261
- 11. Filter element, replacement for Item 3 .....23014
- (-) Power supply (not shown), 120/220 AC to 12-v. DC .....28011
- (-) Sensor (not shown) .....23015
- (-) Orifice, .004 purple restrictor (not shown) ..24423
- (-) Orifice, .006 red restrictor (not shown).....24424
- (-) Fuse, 1-amp (not shown) ..... purchase locally

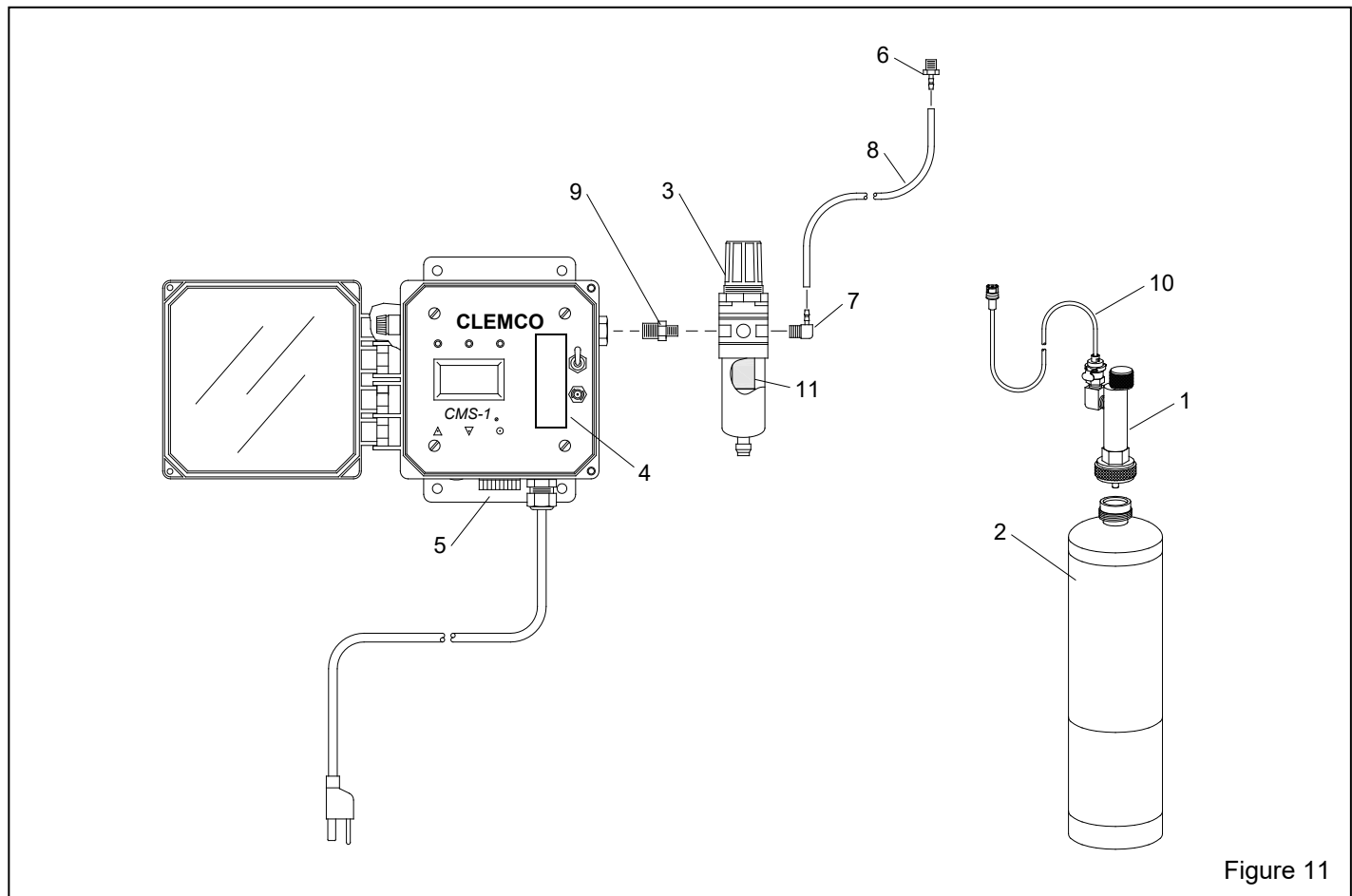

Figure 11

Display shown alternating between current Carbon Monoxide read and LOW FLOW ALARM

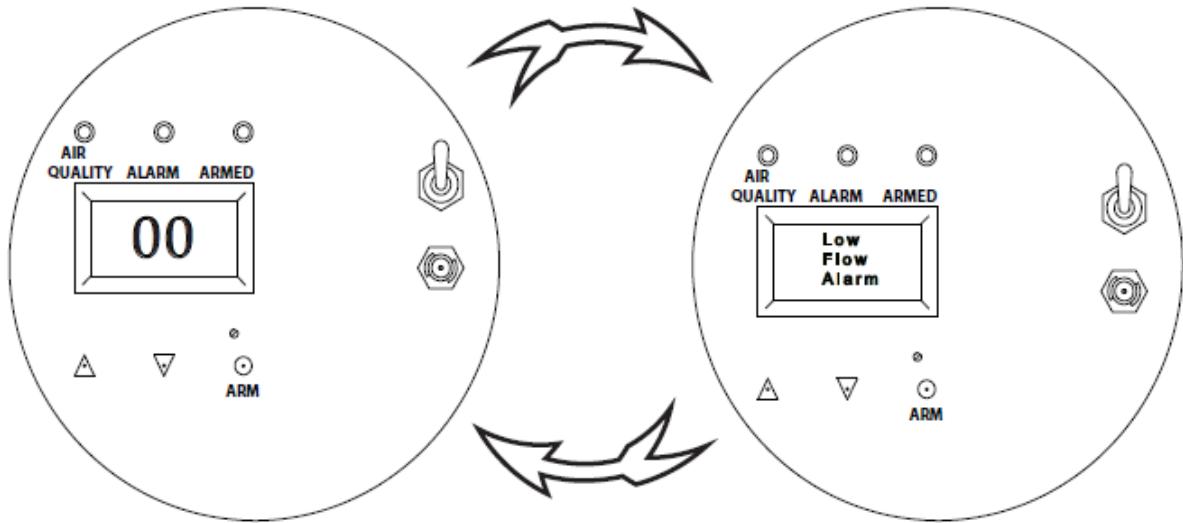

Figure 1