

**HOPPER RECOVERY SYSTEMS  
MODEL 2 x 2 and MODEL 3 x 3  
O. M. 04115**

DATE OF ISSUE: 03/15/74  
REVISION: H, 12/14

 **WARNING**

**Do not use this equipment until you have READ this MANUAL and YOU UNDERSTAND its contents. \***

**These WARNINGS are included for the health and safety of the operator and those in the immediate vicinity.**

**\*If you are using a Clemco Distributor Maintenance and Parts Guide, refer to the orange warnings insert preceding the Index before continuing with the enclosed instructions.**

**Electronic files include a Preface containing important information.**

© 2014 CLEMCO INDUSTRIES CORP.  
One Cable Car Dr.  
Washington, MO 63090  
Phone (636) 239-4300  
Fax (800) 726-7559  
Email: [info@clemcoindustries.com](mailto:info@clemcoindustries.com)  
[www.clemcoindustries.com](http://www.clemcoindustries.com)

**INDUSTRIAL**  
***Blast Facilities***  
by Clemco Industries Corp.

**1.0 INTRODUCTION**

**1.1 Scope**

1.1.1 This manual covers installation, operation, maintenance, troubleshooting, and replacement parts for Clemco 2 x 2 and 3 x 3 hopper recovery systems. Read this entire manual before attempting installation or operation of the recovery hopper. Separate manuals provide instructions on use of equipment in combination with the hoppers. These include the elevator underspeed monitor, abrasive cleaner, blast machine, etc., for additional copies, visit [www.clemcoindustries.com](http://www.clemcoindustries.com) or email [info@clemcoindustries.com](mailto:info@clemcoindustries.com).

1.1.2 All personnel involved with the abrasive blasting process must be made aware of the hazards associated with abrasive blasting. The Clemco booklet "Abrasive Blasting Safety Practices" is included with every blast machine; it contains important safety information about abrasive blasting that may not be included in equipment operation manuals. The booklet is available in both English and Spanish; to request copies, email [info@clemcoindustries.com](mailto:info@clemcoindustries.com).

**1.2 Safety Alerts**

1.2.1 Clemco uses safety alert signal words, based on ANSI Z535.4-2011, to alert the user of a potentially hazardous situation that may be encountered while operating this equipment. ANSI's definitions of the signal words are as follows:

 **This is the safety alert symbol. It is used to alert you to potential physical injury hazards. Obey all safety messages that follow this symbol to avoid possible injury or death.**

**NOTICE**

**Notice indicates information that is considered important, but not hazard-related, if not avoided, could result in property damage.**

**CAUTION**

**Caution indicates a hazardous situation that, if not avoided, could result in minor or moderate injury.**

**WARNING**

**Warning indicates a hazardous situation that, if not avoided, could result in death or serious injury.**

**⚠ DANGER**

**Danger indicates a hazardous situation that, if not avoided, will result in death or serious injury.**

**1.3 Description**

1.3.1 Hopper recovery systems include a shovel-in, surface-mount hopper (2 x 2 system) or sweep-in, floor-level (3 x 3 system) hopper, and bucket elevator. The components of the bucket elevator are shown in Figure 1; their functions are explained in Paragraphs 1.6 through 1.9. The components of the 2 x 2 and 3 x 3 hoppers are shown in Figure 2.

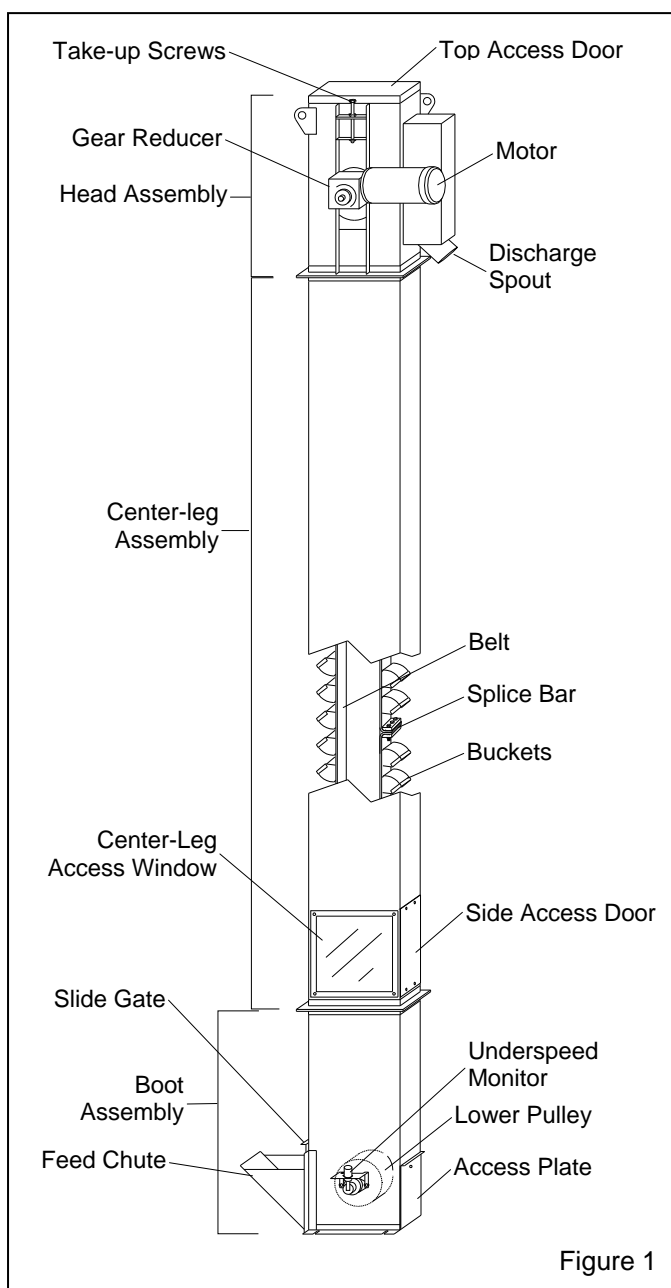

Figure 1

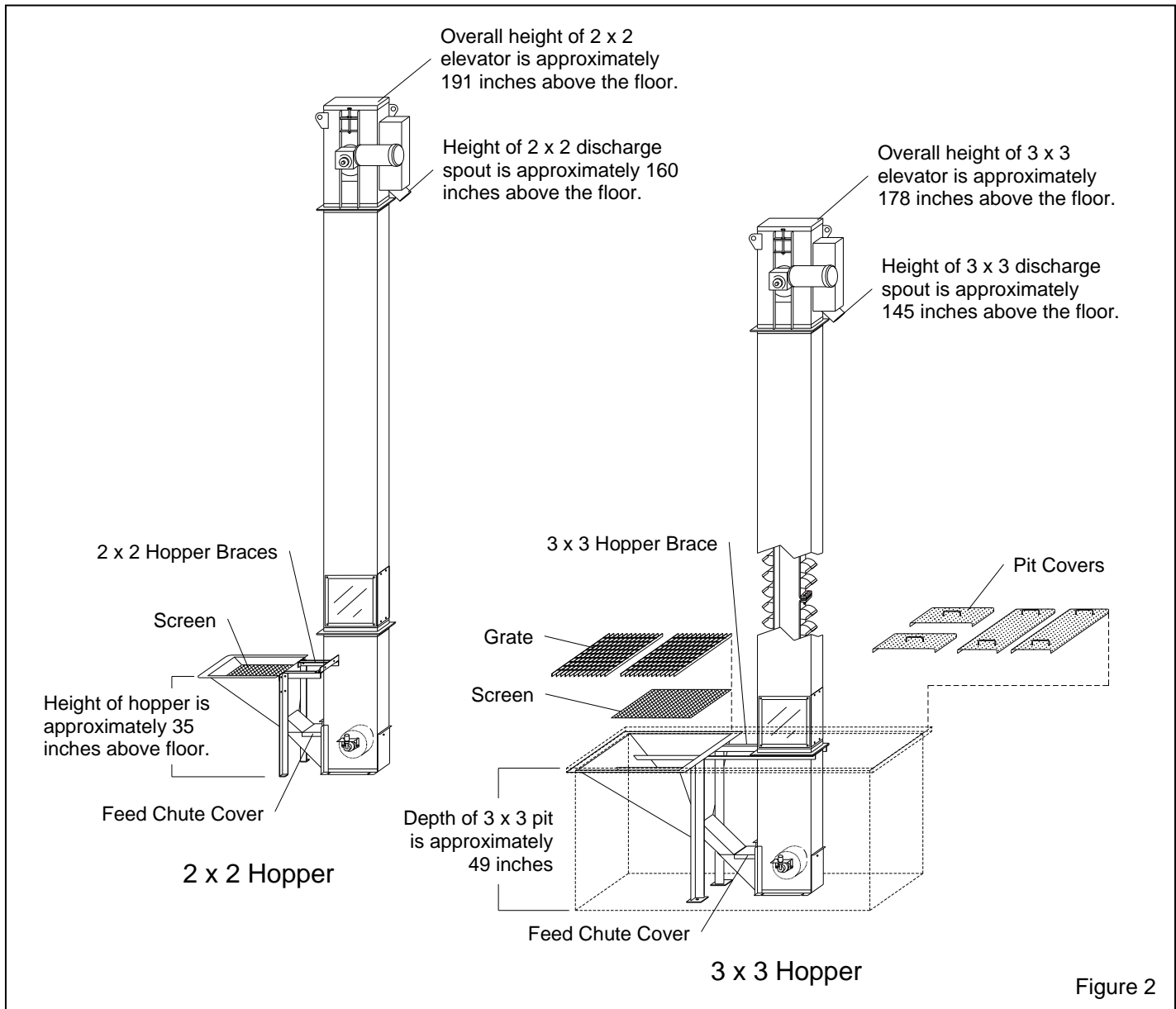

Figure 2

**1.3.2** Hopper Recovery systems are designed to pass through a blast room with maximum thickness of 12 inches. Walls of greater thickness will make elevator assembly difficult. The hopper is located inside the blast room for easy loading, while the elevator and other recovery equipment are kept outside the blast room.

**1.4 Hopper Assemblies**

**1.4.1 2 x 2 Surface Mount Hopper**

**1.4.1.1** The 2 x 2 hopper is surface mounted and does not require a pit. The operator uses a shovel or other means to load the hopper. The top of the hopper is located approximately 35 inches above the floor.

**1.4.2 3 x 3 Recessed Hopper**

**1.4.2.1** The 3 x 3 hopper is recessed into a pit, placing the top of the hopper at floor level. The operator uses a broom, shovel, loader, or similar means to push media into the hopper.

**1.5 Foundation Pit and Anchors**

**1.5.1** Prior to installation of a 3 x 3 system, a foundation pit must be poured. All foundation work is provided by the purchaser. The illustration in Figure 3 is exemplary only, and subject to change. A foundation drawing is provided with the 3 x 3 system, refer to the drawing before excavating and pouring the foundation pit. The illustration in Figure 4 shows the anchor pattern for a 2 x 2 system.

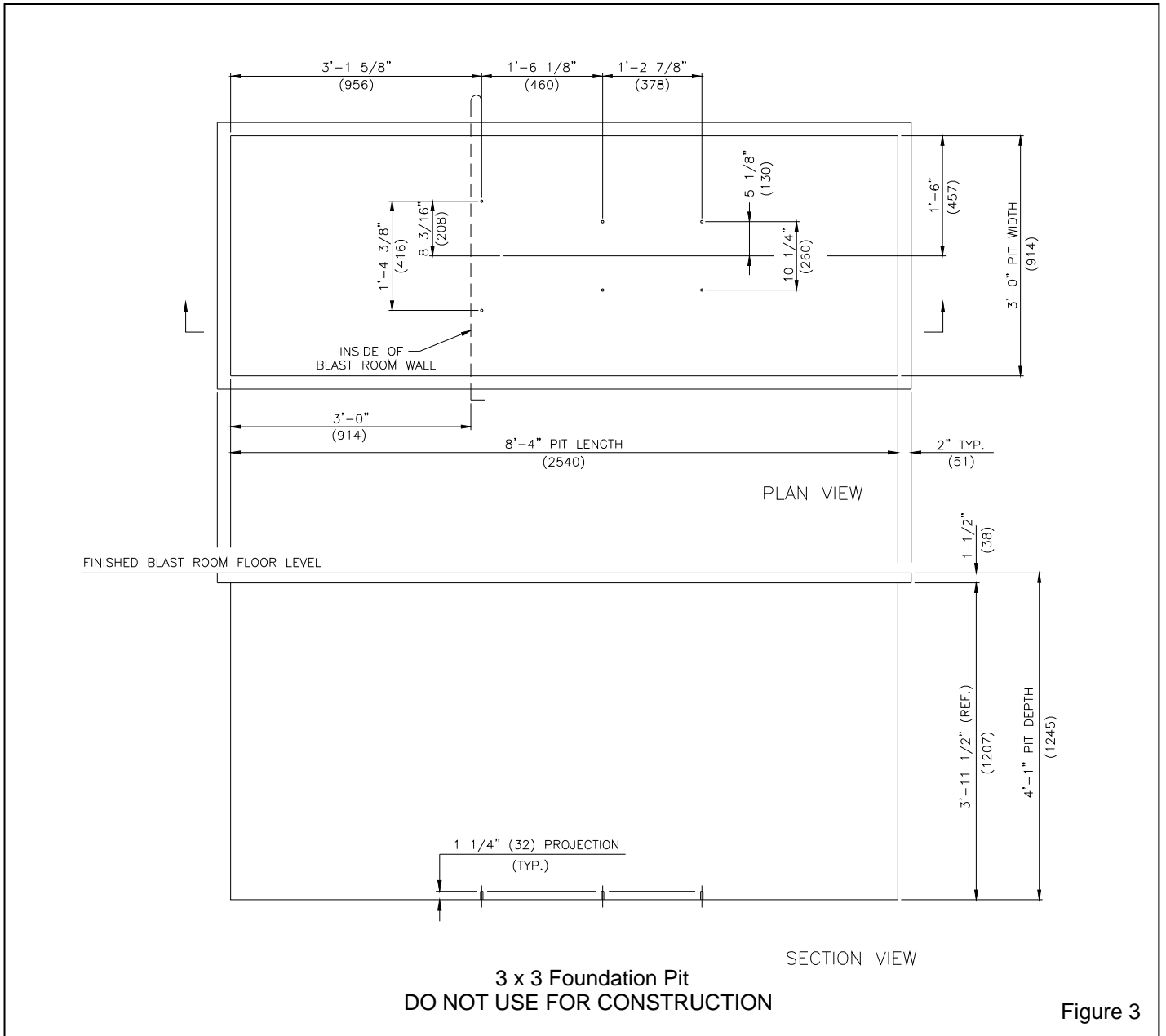

Figure 3

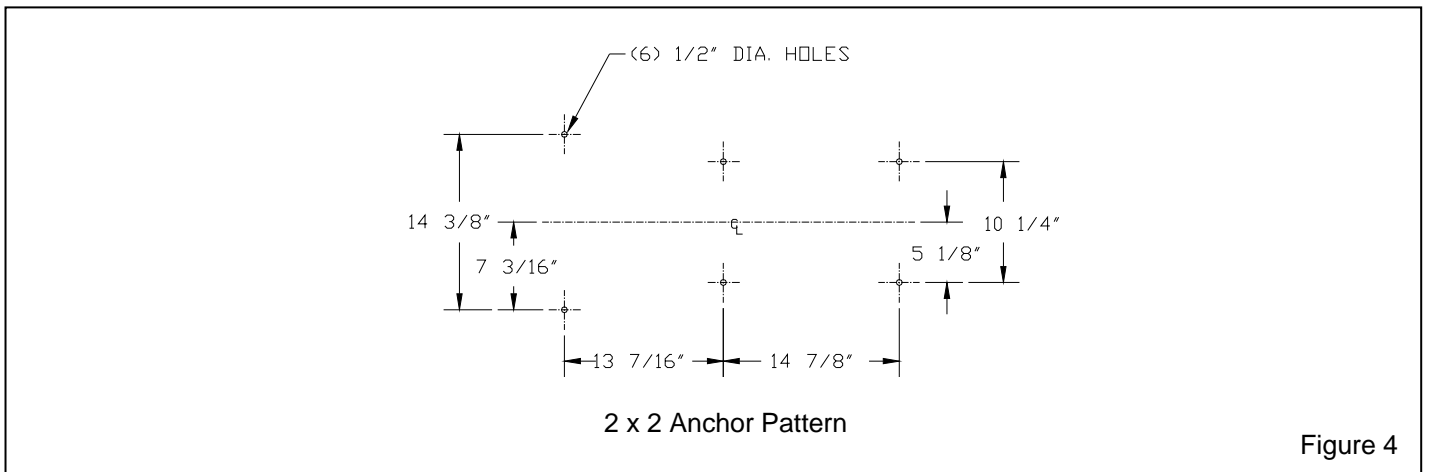

Figure 4

**1.5.2** Specifications on foundation that are included on the drawing are as follows:

- Concrete pit to be level and square to  $\pm 1/8$  inch
- Concrete pit walls to be straight and parallel to  $\pm 1/4$  inch.
- Trowel top and bottom of pit smooth to  $\pm 1/8$  inch.
- Trowel 2" and 1-1/2" shelves smooth to  $\pm 1/8$  inch.
- Hold anchor bolt location  $\pm 1/8$  inch.
- Anchor bolt projection 1-1/4 inch.

## 1.6 Elevator Boot Assembly

With inlet chute, flow control slide gate, lower (idler) pulley, and underspeed monitor.

**1.6.1 The inlet chute:** is the abrasive entry point.

**1.6.2 The flow control slide gate:** meters abrasive into the elevator boot. The gate compensates for the angle of repose of different abrasives, and prevents overloading and jamming from slug-loading abrasive.

**1.6.3 The underspeed monitor:** shuts off the bucket elevator motor (and other recovery equipment) in the event the speed of the lower pulley drops below the monitor's set rpm. It prevents belt slippage burn-through and component damage, in the event of an obstruction jam or a loose belt.

## 1.7 Bucket Elevator Center-Leg

**1.7.1** The center-leg gives the elevator its height. The clear access window permits visual monitoring of the belt movement. The access window is used when adjusting and installing the belt.

## 1.8 Drive Head

**1.8.1** The drive head includes the motor, gear reducer, belt take-up adjusting screws for adjusting the belt tension, and discharge spout.

## 1.9 Belt Assembly with Buckets.

**1.9.1** Buckets, attached to the belt, lift abrasive from the floor-level recovery point, and eject it from the discharge spout.

## 2.0 INSPECTION

**2.1** Inspect for missing or damaged parts.

**2.2** Locate the integrated underspeed monitor owner's manual. It is required for assembly and adjustment.

**2.3** Check bolts on all buckets to insure that none has loosened during shipment.

**2.4** Check the lower corners of the inlet chute for openings. Caulk if necessary.

**2.5** Remove paint on the underspeed monitor rotation indicator tab. Paint may prevent detection from the underspeed proximity switch. Refer to the underspeed monitor manual for additional information.

**2.6** Remove the maintenance sheet supplied with the gear reducer. File it with this manual for future maintenance reference.

## 3.0 INSTALLATION

**Installation Notes:** The following instructions explain the installation of a 3 x 3 system. A 2 x 2 system is assembled similarly, except a foundation pit is not required, and an opening must be made in the blast room wall, and resealed after completing the installation.

These instructions are for the assembly of the recovery hopper and elevator only. Use these instructions in conjunction with other manuals provided with the recovery system. Pay particular attention to the foundation pit, and placement of the elevator with that of the blast machine and abrasive cleaner. For proper abrasive flow from the elevator discharge to the abrasive cleaner inlet, make sure the placement allows a 45° maximum (from vertical) flow-angle between the elevator discharge and abrasive cleaner inlet, as shown in Figure 5.

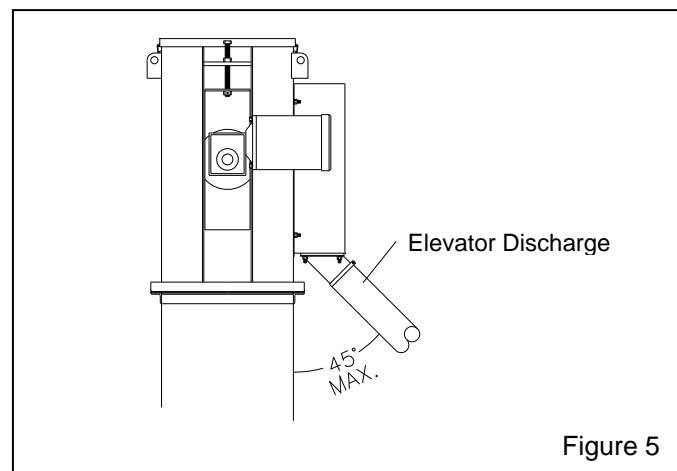

Figure 5

## 3.1 Hopper and Boot Assembly

**3.1.1** Place the elevator boot assembly into the pit from outside the blast room. Lower over the anchor bolts, but do not bolt down at this time.

**3.1.2** Install mastic sealant to the underside of the three hopper flanges that do not against the blast room wall, this assures good contact with the foundation shelf.

**3.1.3** Install the hopper from inside the room, make sure the hopper support legs fit over anchor bolts, and the hopper outlet nestles into the elevator inlet chute.

**3.1.4** The placement of the hopper outlet and elevator inlet chute must be close enough, so the abrasive angle of repose will not allow abrasive to overflow the chute.

**3.1.5** Loosely install hopper braces to the elevator boot. Position the 2 x 2 brace against the elevator, and match drill into the boot.

**Anchor Notes:** If inserts are used instead of poured-in-place anchors, make sure there is room to drill for the anchors, otherwise, mark the hole locations, move hopper and elevator aside and install the inserts.

**3.1.6** Snug-up the anchor nuts and braces but do not tighten at this time. The elevator may require shims between the boot and foundation.

## **⚠ WARNING**

**Weight of an assembled bucket elevator varies with height. A 19' elevator weighs approximately 900 lbs. Erection should be performed by experienced personnel who are familiar with safety hazards associated with handling steel material of this sort, using only approved tools and hoists that are required for safe erection of this product.**

**NOTE:** The following instructions explain in-place assembly of the elevator assembly. If space allows, it may be easier to assemble the elevator on its side then raise the assembled unit into position.

**3.1.7** Make sure the abrasive flow-control slide gate (located between the inlet chute and elevator boot) is in place and has enough clearance to be fully raised or lowered. **The initial setting should place the bottom of the slide gate at mid point of the opening.**

### **3.2 Center-Leg Assembly**

**3.2.1** Apply adhesive-backed strip gasket to the elevator boot and center-leg mating flange.

**3.2.2** Install center-leg (with see-through access window down and facing the most accessible side) to boot, bolting through mating flanges (and 3 x 3 braces).

**3.2.3** Plumb the elevator by putting shims under the elevator boot.

**3.2.4** Tighten all anchors and braces.

### **3.3 Head Assembly**

## **⚠ WARNING**

**To prevent damage or injury from the elevator falling, tie the elevator leg and head sections to a brace that gives them upright support until the completed elevator assembly is bolted down and braced.**

**3.3.1** Lower both take-up adjusting screws to their lowest position.

**3.3.2** Install adhesive-backed strip gasket on the elevator center-leg and head assembly mating flange.

**3.3.3** Place the head assembly onto the center-leg, with the discharge facing the inlet of the next segment, i.e. abrasive cleaner. This should place the discharge chute on the opposite side of the inlet chute. Bolt the head and center-leg together.

**3.3.4** The elevator may require bracing to stabilize it. One method would be to attach diagonal braces from the elevator to the blast room, as shown in Figure 6.

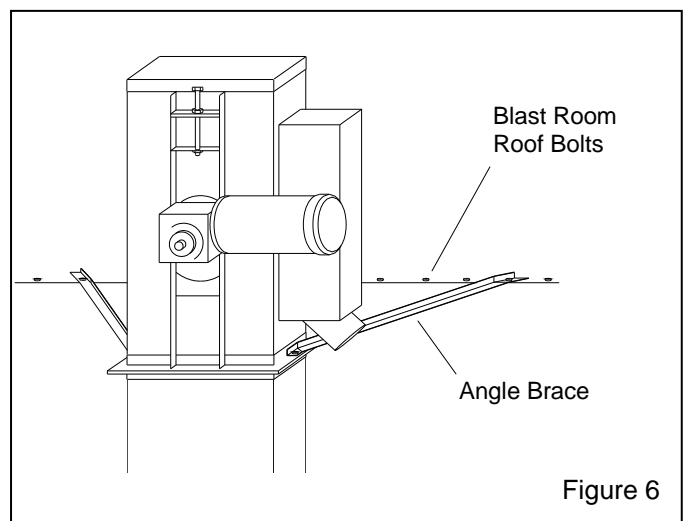

Figure 6

### **3.4 Belt Installation**

**3.4.1** There are two methods of installing the elevator belt assembly, from the top, through the access door in the elevator head or from the side through the access window in the center-leg. Choose the method best suited to the conditions.

## **⚠ WARNING**

**Due to the weight and pull of the elevator belt, the farther the belt is fed into the elevator, the heavier it becomes. Use care when installing or removing the belt assembly. Anyone working at the top access opening must wear a safety belt and work from a safe platform.**

### **3.4.2 Side Installation**

**3.4.2.1** Use this method when there is ample working space around the center-leg opening and the opening is above floor level.

**3.4.2.2** Remove access doors on elevator head, center-leg section and boot section.

**3.4.2.3** From the top access opening, lower a rope down both sides of the upper pulley until both ends reach the center-leg access window. The rope should be looped over the top pulley.

**3.4.2.4** Tie the end of the rope on the discharge side of the elevator to the end of the belt so that when the belt is raised, the buckets on the discharge side face down.

**3.4.2.5** With the help of a second person at the access opening in the elevator head, feed the belt through the center-leg access opening while using the rope to pull the belt up through the elevator.

**3.4.2.6** Continue feeding the belt in until it is fed over the top pulley and down the other side.

**3.4.2.7** Remove the rope from the belt when it is visible again at the access opening.

**3.4.2.8** Continue feeding the belt until the end reaches the bottom of the boot.

**3.4.2.9** Working through the boot access door, make sure the belt is not twisted, and route it under the lower pulley.

**3.4.2.10** Lower a rope from the center-leg access window and attach it to the end of the belt. Pull the rope to bring the end of the belt to the access window. Tie the rope to prevent the belt from falling into the boot.

**3.4.2.11** Proceed to Section 3.5.

### **3.4.3 Top Installation**

**3.4.3.1** Use this method when there is limited space around the center-leg opening and a platform or lift is accessible to the top.

**3.4.3.2** Remove access doors on elevator head, center-leg section and boot section.

**3.4.3.3** Working through the top opening, lower the end of the belt with the buckets facing down, into the discharge side of the top pulley until the end is visible at the center-leg access window. Tie the belt to prevent movement.

**3.4.3.4** Make sure that the buckets will dump toward the discharge spout.

**3.4.3.5** Lower the other end of the belt (buckets facing up) down the other side of the pulley until it reaches the bottom of the boot.

**3.4.3.6** Working through the boot access door, make sure the belt is not twisted, and route it under the lower pulley.

**3.4.3.7** Lower a rope from the center-leg access window and attach it to the end of the belt. Pull the rope to bring the end of the belt to the center-leg access window. Tie the rope to prevent the belt from falling into the boot.

## **3.5 Belt Splicing**

**3.5.1** Draw the two ends of the belt together to determine the overall length and placement of the splice bar.

**3.5.2** Place the splice bars 90 degrees (perpendicular) to the belt. Clamp the splice bars in place and match-drill 3/8" through both ends of the belt. It is important to align the belt as shown in Figure 7. If the splice is misaligned, from not having the splice bar perpendicular to the belt, the belt may tend to drift off the pulley.

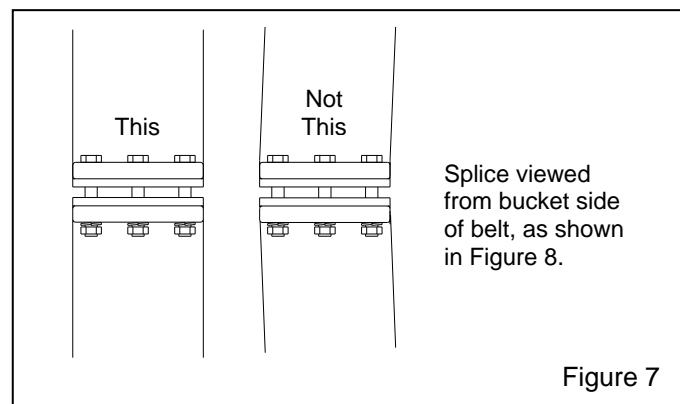
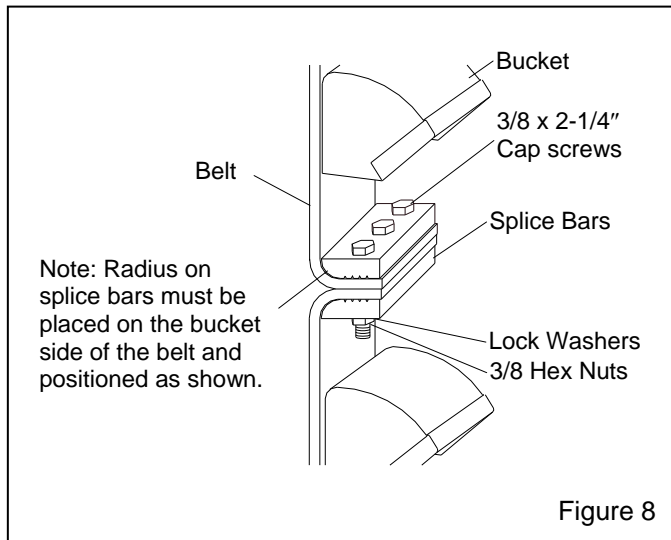

Figure 7

**3.5.3** Install the splice bar as shown in Figure 8, making sure the splice is on the bucket side of the belt. Remove the threading rope. Make sure the splice bar bolts are evenly tightened, and the two ends of the belt are aligned properly, as the splice bar is tightened.

### 3.5.4 Trim off excess belting at splice bar.



**3.5.5** Make sure all ropes, and other tools used during assembly are removed.

**3.6** Raise the belt take-up adjusting screws until the belt is barely taut. It is important that both drive and idle sides are taken up uniformly and that the pulley is level. This will insure the belt tracks in the center of the pulley.

**3.7** Check oil level in gear reducer. If any has leaked during shipment, replace it per instructions supplied with the gear reducer.

**3.8** Refer to the corresponding owner's manual and check installation of all companion equipment (abrasive cleaner, blast machine etc.)

**3.9** The discharge spout may be positioned to face one of three directions. Install it to allow the fewest bends as possible in the discharge hose.

**3.10** Connect the discharge hose to the discharge spout. The angle of the discharge hose must be at least 45 degrees. If the hose sags, put a stiffener on it to prevent it from further sagging under the load of abrasive.

### 3.11 Underspeed Monitor

**3.11.1** Install the underspeed monitor per instructions in the underspeed monitor manual.

**3.12** Install flashing, grout, and otherwise seal the opening between the blast room wall and hopper.

**3.13** Install hopper screen, and grate and cover plates on 3 x 3.

### 3.14 Wiring

NOTE: all wiring is done by the purchaser. Unless an optional control panel was purchased, all motor controls are also provided by the purchaser.

**3.14.1** All components in the system should be wired so they start in series. The last segment in the system should start first. In a complete blast and recovery facility, normally the dust collector starts first, followed by the abrasive cleaner, and bucket elevator. This prevents overloading of any component.

**3.14.2** Have a qualified electrician connect wiring as shown on the motor plate. Motor is 1 HP, 3 PH, 60 HZ.

**3.14.3** Jog the motor to check motor rotation. The belt should move over the top pulley toward the discharge.

### 4.0 Belt Tracking

**4.1** Two people are needed during the initial belt tracking adjustment. While the person making the adjustment observes the belt through the access opening in the bucket elevator head, the other jogs the elevator drive motor.

## **⚠ DANGER**

**Tracking is checked visually through the upper access opening while adjustments are being made. The elevator must be running to insure proper tracking. Extreme care must be taken to keep hands, tools, clothing, etc., away from the opening while the elevator is running. Any limbs, loose clothing, tools or any other articles, catching on a bucket or caught between the belt and pulley will cause severe injury.**

**4.2** Do not run the motor until it is certain the belt tracks correctly. Jog the motor for only a second while monitoring the movement of the belt from the top access opening. Increase the run period by one second until it is certain the belt will track without drifting off the top pulley.

**4.3** After slack has been removed from the belt, and it has been determined that the belt will run without coming off the upper pulley, the motor can be kept running and belt tension can be adjusted per section 5.1.



## 5.0 ADJUSTMENTS

### 5.1 Belt Tension and Tracking

**5.1.1** While the elevator is running, tighten the belt by alternately adjusting the take-up screws, keeping it centered on the upper pulley. The pulley is slightly crowned so the belt will run in the center as long as the take-up screws are moved in unison.

**5.1.2** Shut off the elevator, and lockout and tagout the electrical power.

## **⚠ WARNING**

**Lockout and tagout electrical power before checking belt tension. Unanticipated starting of the elevator could trap limbs, and cause severe injury.**

**5.1.3** Working through the center-leg access opening, use both hands to draw the two sides of the belt together. If the belt is tightened correctly, it cannot be drawn any closer together than between 1-1/2" to 2". See Figure 9.

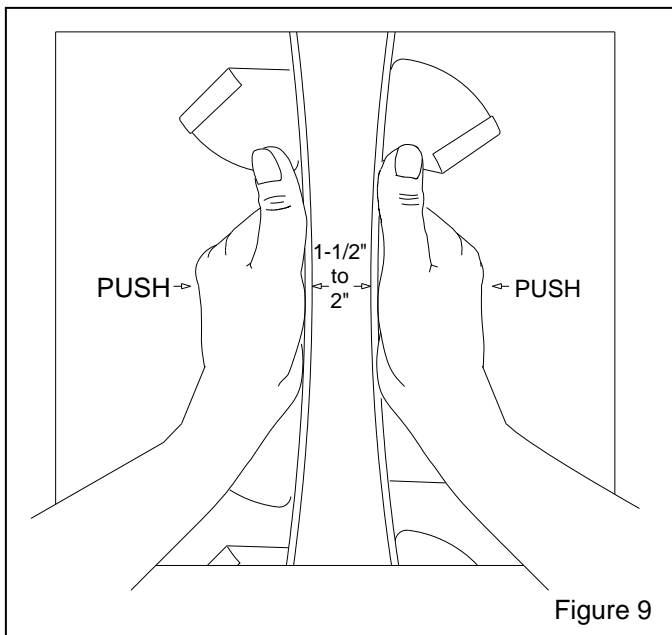

Figure 9

**5.1.4** Check belt tension and adjust as required to obtain correct tension. Be certain to inspect for proper tracking after each adjustment. Once this tension has been established, reactivate the system.

**5.1.5** After the final adjustment is made, belt tracking should be observed for several minutes to ensure there is no long-term drift of the belt on either side of the pulley.

**5.1.6** Install all access covers.

**5.1.7** After the bucket elevator has run for several hours with no load, shut down the system and recheck belt tension.

### 5.2 Underspeed Monitor

**5.2.1** Adjust the underspeed monitor as instructed in the underspeed monitor manual.

### 5.3 Slide Gate

**5.3.1** If abrasive flow is either too great (more abrasive enters the elevator boot than the buckets can carry) or insufficient (abrasive build-up in the inlet chute while buckets are nearly empty), the flow control slide gate should be adjusted.

**5.3.2** When the slide gate is correctly positioned, the buckets pick up a small amount of abrasive on the upward swing at the bottom pulley. Binding at start-up indicates the slide gate is too high.

**5.3.3** Lowering the slide gate reduces flow, raising it increases flow. Always tighten the locking bolt after adjusting the slide gate.

## 6.0 OPERATION

**NOTE:** If the elevator runs for several seconds and shuts off, adjust the underspeed monitor as instructed in the underspeed monitor manual.

**6.1** Run the elevator without abrasive for eight hours. This provides suitable belt break-in, so that initial stretching of the belt can take place.

## **⚠ DANGER**

**Extreme care must be taken to keep hands, tools, clothing, etc., away from moving parts when loading abrasive and checking the operation of the elevator and companion equipment, especially around open cover plates and access doors.**

**6.2** Charge the system with abrasive while all components are running. Care should be used to ensure the system is not overfilled. A standard 2 x 2 and 3 x 3 with abrasive cleaner and 6 cu. ft. blast machine hold approximately 16 cu. ft. of abrasive. When full, the abrasive level will be about 12 inches above the bottom of the abrasive cleaner.

---

**6.3** Check each segment to ensure abrasive is moving correctly, and that there are no abrasive leaks or spills.

**6.4** Install the cover plate onto the inlet chute.

---

## 7.0 MAINTENANCE

---

### **WARNING**

---

**Lockout and tagout electrical power to prevent activation of the elevator during service. Unanticipated starting of the elevator could cause severe injury.**

---

#### 7.1 Belt Tension and Tracking

**7.1.1** During the first week of operation, check belt tension and tracking daily.

**7.1.2** Through the first month, check belt tension and tracking weekly.

**7.1.3** After the initial one-month break-in period, inspect the belt monthly for wear and stretching. Adjust for stretch as covered in Section 5.1.

#### 7.2 Belt Replacement

**7.2.1** Shut off the elevator, and lockout and tagout the electrical power.

**7.2.2** Remove the center-leg access window.

**7.2.3** Rotate the bucket elevator belt until the splice is visible through the access opening.

**7.2.4** Adjust the take-up screws so that the top pulley is at its lowest position.

**7.2.5** Through the leg access opening, attach a rope to the belt on the lower side of the splice. Tie the rope to prevent the belt from falling into the boot when the splice is removed.

**7.2.6** Remove the splice bar assembly from the belt.

**7.2.7** Enlist the aid of another person to work at the top access opening to help feed the belt over the top pulley, and prevent the belt from falling into the elevator.

**7.2.8** Pull the upper end of the belt downward and out through the access window. Doing so will feed the rope under the lower pulley and up and over the top pulley while the old belt is being removed. Use the rope to prevent the old belt from falling as it is removed.

**7.2.9** When the old belt is entirely clear of the elevator, attach the rope to the end of the new belt to facilitate installation per Section 3.4. NOTE! Make sure the belt is installed correctly; when the belt is installed, the open end of the buckets must face toward the discharge.

#### 7.3 Pulleys

**7.3.1** Every six months inspect the upper and lower belt pulleys for wear. Replace the pulleys as needed.

#### 7.4 Gear Reducer

**7.4.1** Check lubricant level monthly.

**7.4.2** Unless stated otherwise in the instructions supplied with the gear reducer, the lubricant should be changed after the first 100 hours of operation. Thereafter, lubricant should be changed every 6 months.

#### 7.4.3 Recommended Lubricant

**7.4.3.1** Follow the instructions supplied with the gear reducer.

#### 7.4.4 Changing Lubricant

**7.4.4.1** Drain oil and flush the gear case with an approved non-flammable, non-toxic solvent, and refill with an approved lubricant.

#### 7.5 Bearing Lubrication

**7.5.1** Lubricate the three idler bearings (one upper and two lower) every 6 months with a good quality general purpose bearing grease.

---

---

## 8.0 TROUBLESHOOTING

### **DANGER**

**Some troubleshooting requires the elevator to be running. Extreme care must be taken to keep hands, tools, clothing, etc., away from the opening while the elevator is running. Any limbs, loose clothing, tools or any other articles, catching on a bucket or caught between the belt and pulley will cause severe injury. When elevator operation is not required, make sure an approved electrical lockout and tagout procedure is done to prevent activation of the elevator during service. Unanticipated starting of the elevator could cause severe injury.**

---

#### 8.1 Elevator Starts, But Shuts Down After Several Seconds.

**8.1.1** Malfunctioning underspeed monitor. Check the adjustment and function of the underspeed monitor as instructed in the underspeed monitor manual.

**8.1.2** Belt may be slipping. Check belt tension.

**8.1.3** Check for obstructions at the inlet chute, discharge spout, or discharge hose.

**8.1.4** Hardened abrasive in elevator boot. Clumps of hardened abrasive will cause buckets to bind.

**8.1.5** Motor overload or breaker tripped. Check the motor and electric circuit for malfunction.

**8.1.6** Slide gate open too far. Too much abrasive entering the boot causes the buckets to bind.

#### 8.2 Elevator Does Not Lift Abrasive.

**8.2.1** Belt may be slipping. Check belt tension.

**8.2.2** Check for blockage in discharge spout and discharge hose.

**8.2.3** Flow control slide gate too low. Adjust per Section 5.3.

#### 8.3 Elevator Making Excessive Noise.

**8.3.1** Check for foreign object in elevator boot.

**8.3.2** Check for loose buckets on belt.

**8.3.3** Belt too loose. Check belt tension.

**8.3.4** Belt may be off-center. Check belt tracking.

**8.3.5** Check for worn pulley bearings.

#### 8.4 Cannot Get Belt to Track

**8.4.1** Belt is not spliced correctly. Refer to Section 3.5, Figure 7.

**8.4.2** Rubber worn on top lagged pulley. Make sure rubber is in place and is in good condition.

#### 8.5 Cannot Tension Belt (too much slack)

**8.5.1** Belt too long. Lower take-up adjusting screws, separate the splice connection and remove excess belt. Re-splice belt ends.

---

**9.0 REPLACEMENT PARTS**

Items without numbered called-outs are not normal replacement parts. Order parts not listed by description and location of parts.

**9.1 Bucket Elevator Assembly, Figure 10**

Item	Description	Stock No.
1.	Motor, 1 HP 1725 RPM TEFC .....	02981
2.	Gear reducer 20:1 .....	25473
3.	Pulley, top lagged 6" diameter x 4" .....	06386
4.	Drive shaft .....	05827
5.	Bearing, flange cartridge .....	06057
6.	Latch (each) .....	10290
7.	Hose, 4" bulk duct, specify length required in feet.....	00716
8.	Clamp, 4-1/2" .....	02806
9.	Belting, 4" wide, bulk, specify length required in feet .....	06414
10.	Belt assembly w/ buckets and splice bar for 2 x 2, 30 ft. ....	06492
	for 3 x 3, 36.5 ft. ....	06491
	for 3 x 3 with 2-pot stand, 44.5 ft. ....	27619
11.	Bucket, polyethylene, each. ....	06486
12.	Washer, 1/4" internal tooth lock.....	03118
13.	Bolt and nut, bucket .....	03119
14.	Gasket, adhesive backed, 5/16" x 3/4" specify length required in feet.....	00189
15.	Pulley, bottom wing, 8" diameter x 6" .....	06385
16.	Idler shaft .....	06409
17.	Door, center access.....	05854
18.	Splice bar assembly .....	06418
19.	Door, side access, 18 x 8 .....	25256
20.	Underspeed monitor assembly .....	20217
	Refer to the underspeed monitor manual for individual replacement parts.	

