

AEROLYTE® By Clemco Industries Corp. Systems

EPRN 4050A Ergonomic Cabinet for Non-aggressive Media*



**High
Performance
Dry Stripping**



Model EPRN 4050A, 2 cu ft blast machine and RPC-2 dust collector

The EPRN Aerolyte 4050A is a high-production ergonomic pressure blast cabinet for dry stripping with plastic or other non-aggressive, recyclable media. Pressure blasting provides the velocity for the impact intensity needed to clean parts without damaging them. The ergonomic design of the EPRN 4050A enhances productivity by providing a comfortable work station for blast operators, making long runs easier by allowing workers to focus on surface preparation, not the physical discomfort of standing.*

Common Applications

- General cleaning of light metals, fiberglass, stainless steel, glass, aluminum and composites
- Deflashing plastic parts
- Paint stripping of powder coated parts, ink wells, golf balls, paint guns, racks, hooks, vehicles, ground support equipment, aircraft
- Cleaning and stripping of molds, tooling, automotive and aircraft engine components, wheels, turbines, semi-conductors, silk screen frames
- Special finishes for sculpture and artwork

*This cabinet is not designed for use with soda media. Bicarbonate of soda, a non-aggressive, single-use media, requires unique equipment considerations. Several Aerolyte cabinet models are available for light-duty or high-production soda blasting. Consult your local authorized Clemco distributor.

Aerolyte Cabinet Features:

Safety

- ✓ Full-length, neoprene-on-fabric gloves resist wear and protect operator.
- ✓ Ceiling-mounted, two-tube fluorescent light fixture with abrasive resistant cover for extraordinary visibility.
- ✓ Safety interlocks interrupt blasting if door is opened.
- ✓ Pressure relief valve, set at 65 psi, automatically opens to signal higher pressure blasting to prevent surface damage.

Productivity

- ✓ 2 cubic foot capacity, epoxy-lined pressure vessel with 60° conical bottom, 1" ID piping, 3/4" ID x 16 ft coupled blast hose, and controls.
- ✓ Adjustable vortex prevents media carryover to dust collector.
- ✓ Air logic system maximizes air flow to the nozzle.
- ✓ Adjustable foot rest.
- ✓ Double-wall, sound-insulated doors.
- ✓ Large 12.5" x 19.5" view window.
- ✓ Operator comfort enhances productivity.

Convenience

- ✓ Tilt-out window, for tool-free glass changes in minutes.
- ✓ Pressure regulator, gauge, and electric switch mounted within easy reach.
- ✓ Built-in air blow-off aids monitoring part cleaning progress and removes excess media.



Tungsten Carbide Blast Nozzle

The TYP-5 (5/16-inch orifice) tungsten carbide nozzle is ideal for most blasting jobs.

Popular Options

- Air-powered vertical lift door
- Armrest assembly
- HEPA filter
- Magnetic reclaim screen
- Manometer kit
- Noise reduction arm port baffles
- Oscillator assembly
- Storage hopper, 2 cu ft
- Timed door release
- 20" and 30" dia. turntables
- 20" or 30" turntable (500 lb capacity) with 8 foot track extension

S P E C I F I C A T I O N S

COMPLETE SYSTEM

Space required depends on configurations, options and work flow. Allow space for operator and maintenance access. See maintenance access height (MAH) below.

Blast machine and reclaim

G - 48" diam. (121.9 cm)
H - 91.25" high (231.8 cm)

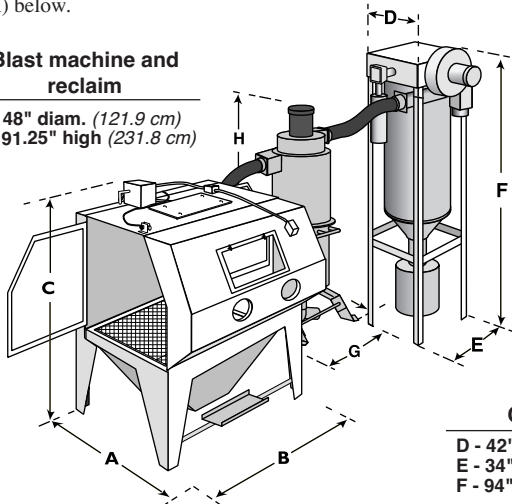

EPCN 4050 A

A - 40" (101.6 cm)
B - 56" (142.2 cm)
C - 83.5" (212.1 cm)

CDC-1

D - 42" (106.7 cm)
E - 34" (191.4 cm)
F - 94" (238.8 cm)

EPCN 4050 A

CABINET

Working Chamber Size

EPRN 4050A
50" wide (1270 mm)
39" deep (991 mm)*
43" high (1092 mm)

*(for ergo models add 12 inches to depth)

Window Size (safety glass)

19.5" wide (49.5 cm)
12.5" high (31.7 cm)

Door Opening

A - 27" (686 mm)
B - 20.5" (521 mm)
C - 19.5" (495 mm)
D - 36.5" (927 mm)
E - 38" (965 mm)

Ergonomic Configuration

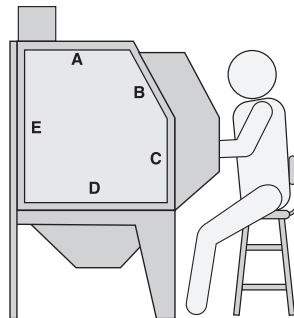

DUST COLLECTORS

ZERO RP dust collectors trap 99.7% of dust particles down to 0.5 micron.

CDC-1

CDC-1 dust collectors come in three sizes; 300 cfm, 600 cfm, and 900 cfm. The cartridges are pulse-cleaned by pressing the manual pulse-valve to clear the filter of dust. Dimensions are 34" wide, 42" deep (with motor housing) and 94" high. MAH is 11 ft for the 300 cfm and 600 cfm units and 12-1/2 ft for the 900 cfm unit.

RPC-2

The RPC-2 has two cartridges which provide 470 sq ft of filter area. The cartridges are automatically pulse-cleaned for maximum filter efficiency. Dimensions are: 56" wide (with motor housing) by 30" deep by 67.5" high. The MAH for the RPC-2 series is 8 ft 10 inches.

RPH-2

The RPH-2 has a filter area of 470 sq ft; the RPH-3 has a 705 sq ft filter area. Both have a built-in hopper to minimize dust-handling. At each pulse, dust falls first into the hopper and then into a disposal drum or bag beneath it. The operator never handles the dust—an important safety feature. RPH dust collector dimensions are: 56" wide (with motor housing) by 36" deep by 115" high. The RPH is designed to allow outdoor installation. The MAH for the RPH collectors is 15 ft 2 inch.

BLAST/ RECLAIM SYSTEM

Our exclusive media reclaimers continuously extract dust and debris and return usable media to the blast system.

The reclaimer, mounted atop the pressure vessel, automatically refills the blast system with clean, recycled media each time the foot pedal is released.

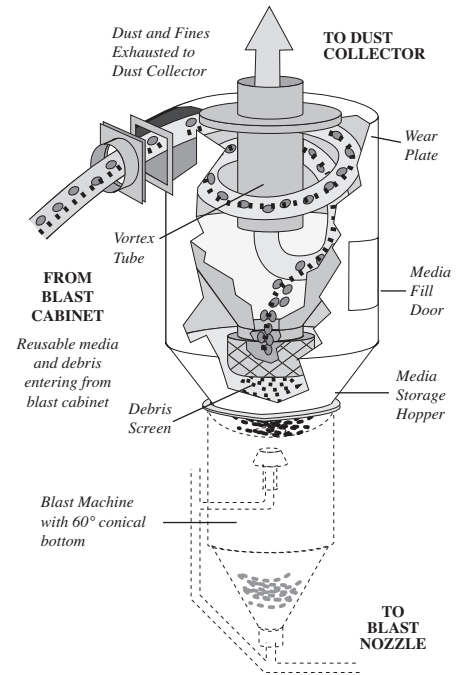

NOZZLES

AIR REQUIREMENTS

NOZZLE	NOZZLE ORIFICE	CFM at 50 PSI	M ³ /Min at 3,5 BAR
No. 5	5/16"	77	2,16*

* PCN 4050 A comes with a No. 5 tungsten carbide nozzle.

ELECTRICAL

900 CFM (25 m³/m) 2HP, 230/460V, 3PH, 60HZ (1.5KW, 220V, 3PH, 50HZ,)

Other motors and electrical configurations may be available to make your system compatible with local power systems. Consult your local distributor.

ORDERING INFORMATION

Model Number	Reclaim CFM (m ³ /m)	Dust Collector	Stock No.	Ship Wt. lb (kg)
EPDN 4050 A	900 (25)	CDC-1	25041	1,490 (676)
EPRN 4050 A	900 (25)	RPC-2	25042	1,815 (823)
EPRH 4050 A	900 (25)	RPH	25043	2,390 (1084)

Distributor:

ISO 9001 certified. Clemco is committed to continuous product improvement. Specifications are subject to change without notice.

© 2016 Clemco Industries Corp. • Washington, MO 63090 • 636 239-4300 • FAX 800 726-7559

Stock No. 27577

info@clemcoindustries.com • www.clemcoindustries.com

Date of issue: Rev. A 04/16