

INTEGRATED UNDERSPEED MONITOR

O.M. 21431

MC FILE NUMBER: 1161-0195

DATE OF ISSUE: 02/96

REVISION: C, 12/09

WARNING

Do not proceed with these instructions* until you have READ the orange cover of this MANUAL and YOU UNDERSTAND its contents.

These WARNINGS are included for the health and safety of the operator and those in the immediate vicinity.

***If you are using a Clemco Distributor Maintenance and Part Guide, refer to the orange warnings insert preceding the Index before continuing with the enclosed instructions.**

Electronic files include a Preface containing the same important information as the orange cover.

© 2009 CLEMCO INDUSTRIES CORP.

One Cable Car Dr.

Washington, MO 63090

Phone (636) 239-4300

Fax (800) 726-7559

Email: info@clemcoindustries.com

www.clemcoindustries.com

INDUSTRIAL
Blast Facilities
by Clemco Industries Corp.

⚠ WARNING

- Read and follow ALL instructions before using this equipment.
- Failure to comply with ALL instructions can result in serious injury or death.
- In the event that the user, or any assistants of the user of this equipment cannot read or cannot completely understand the warnings and information contained in these instructions, the employer of the user and his assistants must thoroughly educate and train them on the proper operation and safety procedures of this equipment.

NOTICE TO PURCHASERS AND USERS OF OUR PRODUCTS AND THIS INFORMATIONAL MATERIAL

The products described in this material, and the information relating to those products, is intended for knowledgeable, experienced users of abrasive blasting equipment.

No representation is intended or made as to the suitability of the products described herein for any particular purpose or application. No representations are intended or made as to the efficiency, production rate, or the useful life of the products described herein. Any estimate regarding production rates or production finishes are the responsibility of the user and must be derived solely from the user's experience and expertise, and must not be based on information in this material.

The products described in this material may be combined by the user in a variety of ways for purposes determined solely by the user. No representations are intended or made as to the suitability or engineering balance of the combination of products determined by the user in his selection, nor as to the compliance with regulations or standard practice of such combinations of components or products.

Abrasive Blast Equipment is only a component of the range of equipment used in an abrasive blasting job. Other products may include an air compressor, abrasive, scaffolding, hydraulic work platforms or booms, paint spray equipment, dehumidification equipment, air filters and receivers, lights, ventilation equipment, parts handling equipment, specialized respirators, or equipment that while offered by Clemco may have been supplied by others. Each manufacturer and supplier of the other products used in the abrasive blasting job must be contacted for information, training, instruction and warnings with regard to the proper and safe use of their equipment in the particular application for which the equipment is being used. The information provided by Clemco is intended to provide instruction only on Clemco products. All operators must be trained in the proper, safe, use of this equipment. It is the responsibility of the users to familiarize themselves with, and comply with, all appropriate laws, regulations, and safe practices that apply to the use of these products. Consult with your employer about training programs and materials that are available.

Our company is proud to provide a variety of products to the abrasive blasting industry, and we have confidence that the professionals in our industry will utilize their knowledge and expertise in the safe efficient use of these products.

GENERAL INSTRUCTIONS

Described herein are some, **BUT NOT ALL**, of the major requirements for safe and productive use of blast machines, remote control systems, operator respirator assemblies, and related accessories. Completely read **ALL** instruction manuals prior to using equipment.

The user's work environment may include certain **HAZARDS** related to the abrasive blasting operation. Proper protection for the blaster, as well as anyone else that may be **EXPOSED** to the hazards generated by the blasting process, is the responsibility of the user and/or the employer. Operators **MUST** consult with their employer about what hazards may be present in the work environment including, but not limited to, exposure to dust that may contain **TOXIC MATERIALS** due to the presence of silica, cyanide, arsenic or other toxins in the abrasive, or materials present in the surface to be blasted such as lead or heavy metals in coatings. The environment may also include fumes that may be present from adjacent coatings application, contaminated water, engine exhaust, chemicals, and asbestos. The work area may include **PHYSICAL HAZARDS** such as an uneven work surface, poor visibility, excess noise, and electrical hazards. The operator **MUST** consult with his employer on the identification of potential hazards, and the appropriate measures that **MUST** be taken to protect the blaster and others that might be exposed to these hazards.

ALL machines, components and accessories **MUST** be installed, tested, operated and maintained only by trained, knowledgeable, experienced users.

DO NOT modify or substitute any Clemco parts with other types or brands of equipment. Unauthorized modification and parts substitution on supplied air respirators is a violation of OSHA regulations and voids the NIOSH approval.

OPERATIONAL INSTRUCTIONS

OPERATOR SAFETY EQUIPMENT

⚠ WARNING

- Blast operators and others working in the vicinity of abrasive blasting must always wear properly-maintained, NIOSH-approved, respiratory protection appropriate for the job site hazards.
- **DO NOT USE** abrasives containing more than one percent crystalline (free) silica. Ref. NIOSH Alert #92-102
- Inhalation of toxic dust (crystalline silica, asbestos, lead paint and other toxins) can lead to serious or fatal disease (silicosis, asbestosis, lead or other poisoning).

- **ALWAYS** wear NIOSH-approved supplied-air respirators as required by OSHA, in the presence of any dust including, but not limited to, handling or loading abrasive; blasting or working in the vicinity of blast jobs; and cleanup of expended abrasive. Prior to removing respirator, an air monitoring

instrument should be used to determine when surrounding atmosphere is clear of dust and safe to breathe.

- NIOSH-approved, supplied-air respirators are to be worn ONLY in atmospheres:
 - NOT IMMEDIATELY dangerous to life or health and,
 - from which a user can escape WITHOUT using the respirator.
- Clemco supplied-air respirators **DO NOT REMOVE OR PROTECT AGAINST CARBON MONOXIDE (CO) OR ANY OTHER TOXIC GAS.** Carbon monoxide and toxic gas removal and/or monitoring device must be used in conjunction with respirator to insure safe breathing air.
- Air supplied to respirator **MUST BE AT LEAST GRADE D QUALITY** as described in Compressed Gas Association Commodity Specification G-7.1, and as specified by OSHA Regulation 1910.139 (d).
- ALWAYS locate compressors to prevent contaminated air (such as CO from engine exhaust) from entering the air intake system. A suitable in-line air purifying sorbent bed and filter or CO Monitor should be installed to assure breathing air quality.
- ALWAYS use a NIOSH-approved breathing air hose to connect an appropriate air filter to the respirator. Use of a non-approved air hose can subject the operator to illness caused by the release of chemical agents used in the manufacture of non-approved breathing air hose.
- ALWAYS check to make sure air filter and respirator system hoses are NOT CONNECTED to in-plant lines that contain nitrogen, acetylene or any other non-breathable gas. NEVER use oxygen with air line respirators. NEVER modify air line connections to accommodate air filter/respirator breathing hose WITHOUT FIRST testing content of the air line. **FAILURE TO TEST THE AIR LINE MAY RESULT IN DEATH TO THE RESPIRATOR USER.**
- Respirator lenses are designed to protect against rebounding abrasive. They do not protect against flying objects, glare, liquids, radiation or high speed heavy materials. Substitute lenses from sources other than the original respirator manufacturer will void NIOSH-approval of this respirator.

BLAST MACHINES AND REMOTE CONTROLS

 WARNING
<ul style="list-style-type: none"> • ALWAYS equip abrasive blast machines with remote controls. • Abrasive blast machine operators must wear NIOSH-approved supplied-air respirators (ref: OSHA regulations 1910.94, 1910.132, 1910.139 and 1910.244).

- NEVER modify OR substitute remote control parts. Parts from different manufacturers are NOT compatible with Clemco

equipment. If controls are altered, involuntary activation, which may cause serious injury, can occur.

- Inspect the air control orifice DAILY for cleanliness. NEVER use welding hose in place of twinline control hose. The internal diameter and rubber composition are UNSAFE for remote control use.
- UNLESS OTHERWISE SPECIFIED, maximum working pressure of blast machines and related components MUST NOT exceed National Board approved 125 psig (8.5 BAR).
- NEVER weld on blast machine. Welding may affect dimensional integrity of steel wall and WILL VOID National Board approval.
- Point nozzle ONLY at structure being blasted. High velocity abrasive particles WILL inflict serious injury. Keep unprotected workers OUT of blast area.
- NEVER attempt to manually move blast machine when it contains abrasive. EMPTY machines, up to 6 cu. ft.(270kg) capacity, are designed to be moved:
 - on flat, smooth surfaces by AT LEAST two people;
 - with the Clemco "Mule"; or
 - with other specially designed machine moving devices.
- Larger empty blast machines or ANY blast machine containing abrasive MUST be transported by mechanical lifting equipment.

AIR HOSE, BLAST HOSE, COUPLINGS, AND NOZZLE HOLDERS

- Air hose, air hose fittings and connectors at compressors and blast machines MUST be FOUR times the size of the nozzle orifice. Air hose lengths MUST be kept as short as possible AND in a straight line. Inspect DAILY and repair leakage IMMEDIATELY.
- Blast hose inside diameter MUST be THREE to FOUR times the size of the nozzle orifice. AVOID sharp bends that wear out hose rapidly. Use SHORTEST hose lengths possible to reduce pressure loss. Check blast hose DAILY for soft spots. Repair or replace IMMEDIATELY.
- ALWAYS cut loose hose ends square when installing hose couplings and nozzle holders to allow uniform fit of hose to coupling shoulder. NEVER install couplings or nozzle holders that DO NOT provide a TIGHT fit on hose. ALWAYS use manufacturers recommended coupling screws.
- Replace coupling gaskets FREQUENTLY to prevent leakage. Abrasive leakage can result in dangerous coupling failure. ALL gaskets MUST be checked SEVERAL times during a working day for wear, distortion and softness.
- Install safety pins at EVERY coupling connection to prevent accidental disengagement during hose movement.
- ALWAYS attach safety cables at ALL air hose AND blast hose coupling connections. Cables relieve tension on hose and control whipping action in the event of a coupling blow-out.

MAINTENANCE

- ALWAYS shut off compressor and depressurize blast machine BEFORE doing ANY maintenance.
- Always check and clean ALL filters, screens and alarm systems when doing any maintenance.
- ALWAYS cage springs BEFORE disassembling valves IF spring-loaded abrasive control valves are used.
- ALWAYS completely follow owner's manual instructions and maintain equipment at RECOMMENDED intervals.

ADDITIONAL ASSISTANCE

- Training and Educational Programs. Clemco Industries Corp. offers a booklet, Blast-Off 2, developed to educate personnel on abrasive blast equipment function and surface preparation techniques. Readers will learn safe and productive use of machines, components and various accessories, including selection of abrasive materials for specific surface profiles and degrees of cleanliness.
- The Society for Protective Coatings (SSPC) offers a video training series on protective coatings including one entitled "Surface Preparation." For loan or purchase information, contact SSPC at the address shown below.

TECHNICAL DATA AND RESEARCH COMMITTEES

- The following associations offer information, materials and videos relating to abrasive blasting and safe operating practices.

The Society for Protective Coatings (SSPC)
 40 24th Street, Pittsburgh PA 15222-4643
 Phone: (412) 281-2331 • FAX (412) 281-9992
 Email: research@sspc.org • Website: www.sspc.org

National Association of Corrosion Engineers (NACE)
 1440 South Creek Drive, Houston TX 77084
 Phone: (281) 228-6200 • FAX (281) 228-6300
 Email: msd@mail.nace.org • Website: www.nace.org

American Society for Testing and Materials (ASTM)
 100 Barr Harbor Dr., West Conshohocken, PA 19428
 Phone (610) 832-9500 • FAX (610) 832-9555
 Email: service@astm.org • Website: www.astm.org

NOTICE

This equipment is not intended to be used in an area that might be considered a hazardous location as described in the National Electric Code NFPA 70 1996, article 500.

WARRANTY

The following is in lieu of all warranties express, implied or statutory and in no event shall seller or its agents, successors, nominees or assignees, or either, be liable for special or consequential damage arising out of a breach of warranty. This warranty does not apply to any damage or defect resulting from negligent or improper assembly or use of any item by the buyer or its agent or from alteration or attempted repair by any person other than an authorized agent of seller. All used, repaired, modified or altered items are purchased "as is" and with all faults. In no event shall seller be liable for consequential or incidental damages. The sole and exclusive remedy of buyer for breach of warranty by seller shall be repair or replacement of defective parts or, at seller's option, refund

of the purchase price, as set forth below:

1. Seller makes no warranty with respect to products used other than in accordance hereunder.
2. On products seller manufactures, seller warrants that all products are to be free from defects in workmanship and materials for a period of one year from date of shipment to buyer, but no warranty is made that the products are fit for a particular purpose.
3. On products which seller buys and resells pursuant to this order, seller warrants that the products shall carry the then standard warranties of the manufacturers thereof, a copy of which shall be made available to customer upon request.
4. The use of any sample or model in connection with this order is for illustrative purposes only and is not to be construed as a warranty that the product will conform to the sample or model.
5. Seller makes no warranty that the products are delivered free of the rightful claim of any third party by way of patent infringement or the like.
6. This warranty is conditioned upon seller's receipt within ten (10) days after a buyer's discovery of a defect, of a written notice stating in what specific material respects the product failed to meet this warranty. If such notice is timely given, seller will, at its option, either modify the product or part to correct the defect, replace the product or part with complying products or parts, or refund the amount paid for the defective product, any one of which will constitute the sole liability of seller and a full settlement of all claims. No allowance will be made for alterations or repairs made by other than those authorized by seller without the prior written consent of seller. Buyer shall afford seller prompt and reasonable opportunity to inspect the products for which any claim is made as above stated.

Except as expressly set forth above, all warranties, express, implied or statutory, including implied warranty of merchantability, are hereby disclaimed.

DAILY SET-UP CHECK LIST

 WARNING
<ul style="list-style-type: none"> • ALL piping, fittings and hoses MUST be checked DAILY for tightness and leakage. • ALL equipment and components MUST be thoroughly checked for wear. • ALL worn or suspicious parts MUST be replaced. • ALL blast operators MUST be properly trained to operate equipment. • ALL blast operators MUST be properly outfitted with abrasive resistant clothing, safety shoes, leather gloves and ear protection. • BEFORE blasting ALWAYS use the following check list.

1. PROPERLY MAINTAINED AIR COMPRESSOR sized to provide sufficient volume (cfm) for nozzle and other tools PLUS a 50% reserve to allow for nozzle wear. Use large compressor outlet and large air hose (4 times the nozzle orifice size). FOLLOW MANUFACTURERS MAINTENANCE INSTRUCTIONS.

2. BREATHING AIR COMPRESSOR (oil-less air pump) capable of providing Grade D Quality air located in a dust free, contaminant free area. If oil-lubricated air compressor is used to supply respirator, it should have high temperature monitor and CO monitor or both. If CO monitor is not used, air **MUST** be tested FREQUENTLY to ensure proper air quality.

3. Clean, properly maintained NIOSH-APPROVED SUPPLIED-AIR RESPIRATOR. ALL components should ALWAYS be present. NEVER operate without inner lens in place. Thoroughly inspect ALL components DAILY for cleanliness and wear. ANY substitution of parts voids NIOSH approval i.e. cape, lenses, breathing hose, breathing air supply hose, air control valve, cool air or climate control devices.

4. OSHA required BREATHING AIR FILTER for removal of moisture and particulate matter from breathing air supply. THIS DEVICE DOES NOT REMOVE OR DETECT CARBON MONOXIDE (CO). ALWAYS USE CO MONITOR ALARM.

5. ASME CODED BLAST MACHINE sized to hold 1/2 hour abrasive supply. ALWAYS ground machine to eliminate static electricity hazard. Examine pop up valve for alignment. Blast machine MUST be fitted with a screen to keep out foreign objects and a cover to prevent entry of moisture overnight.

6. AIR LINE FILTER installed AS CLOSE AS POSSIBLE to machine inlet. Sized to match inlet piping or larger air supply line. Clean filter DAILY. Drain OFTEN.

7. REMOTE CONTROLS MUST be in PERFECT operating condition. ONLY use APPROVED spare parts, including twin-line hose. DAILY: test system operation and check button bumper and spring action of lever and lever lock. DO NOT USE WELDING HOSE.

8. BLAST HOSE with ID 3 to 4 times the nozzle orifice. Lines MUST be run AS STRAIGHT AS POSSIBLE from machine to work area with NO sharp bends. Check DAILY for internal wear and external damage.

9. HOSE COUPLINGS, NOZZLE HOLDERS fitted SNUGLY to hose end and installed using PROPER coupling screws. Coupling lugs MUST be snapped FIRMLY into locking position. Gasket MUST form positive seal with safety pins inserted through pin holes. Check gaskets and replace if ANY sign of wear, softness or distortion. ALWAYS install safety cables at every connection to prevent disengagement. Check nozzle holder for worn threads. NEVER MIX DIFFERENT BRANDS OF COMPONENTS. Check each of these components DAILY.

10. Inspect NOZZLE and GASKET DAILY for wear. Replace nozzle when 1/16" larger than original size or if liner appears cracked. Check nozzle threads for wear.

11. Use abrasive that is properly sized and free of harmful substances; such as, free silica, cyanide, arsenic or lead. Check material data sheet for presence of toxic or harmful substances.

12. Test surface to be blasted for toxic substances. Take appropriate, and NIOSH required, protective measures for operator and bystanders which pertain to substances found on the surface to be blasted.

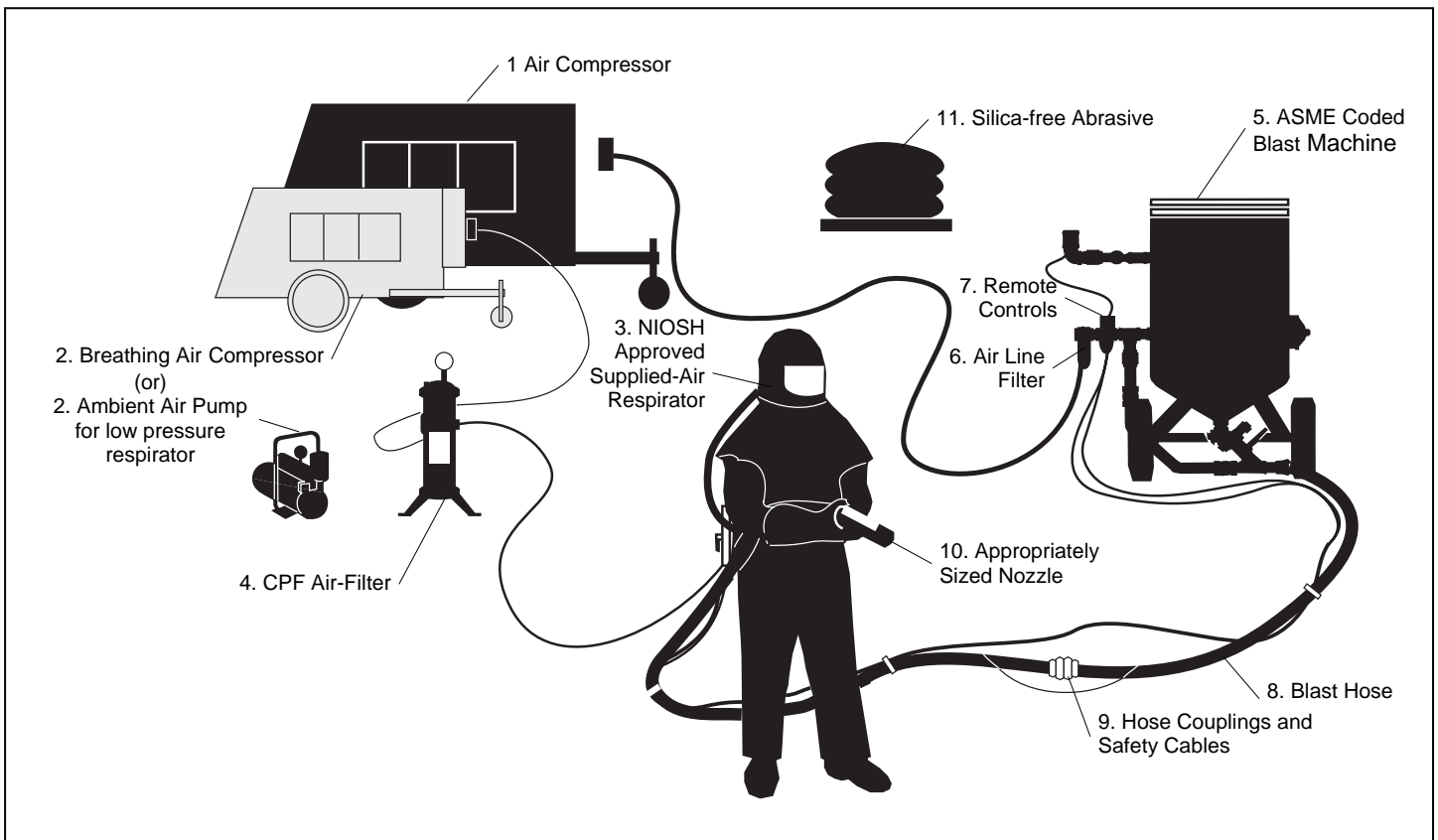

1.0 INTRODUCTION

1.1 **Scope:** These instructions cover the installation, adjustments, and replacement parts of the integrated underspeed monitor (proximity switch) used with Clemco bucket elevator recovery systems.

1.2 Safety Alerts

1.2.1 Clemco uses safety alert signal words, based on ANSI Z535.4-1998, to alert the user of a potentially hazardous situation that may be encountered while operating this equipment. ANSI's definitions of the signal words are as follows:



This is the safety alert symbol. It is used to alert the user of this equipment of potential personal injury hazards.

Obey all safety messages that follow this symbol to avoid possible injury or death.

CAUTION

Caution used without the safety alert symbol indicates a potentially hazardous situation which, if not avoided, may result in property damage.

CAUTION

Caution indicates a potentially hazardous situation which, if not avoided, may result in minor or moderate injury.

WARNING

Warning indicates a potentially hazardous situation which, if not avoided, could result in death or serious injury.

DANGER

Danger indicates an imminently hazardous situation which, if not avoided, will result in death or serious injury.

1.3 **General Description:** The illustration in Figure 1 shows the monitor assembly installed on a front feed bucket elevator. The monitor detects the motion of the elevator bottom (idler) pulley. It is designed to shut off the bucket elevator motor in the event the speed of the bottom pulley drops below the monitor's set RPM. This will prevent burn-through, and component damage in the event of an obstruction, jam, or belt slippage, in the bucket elevator.

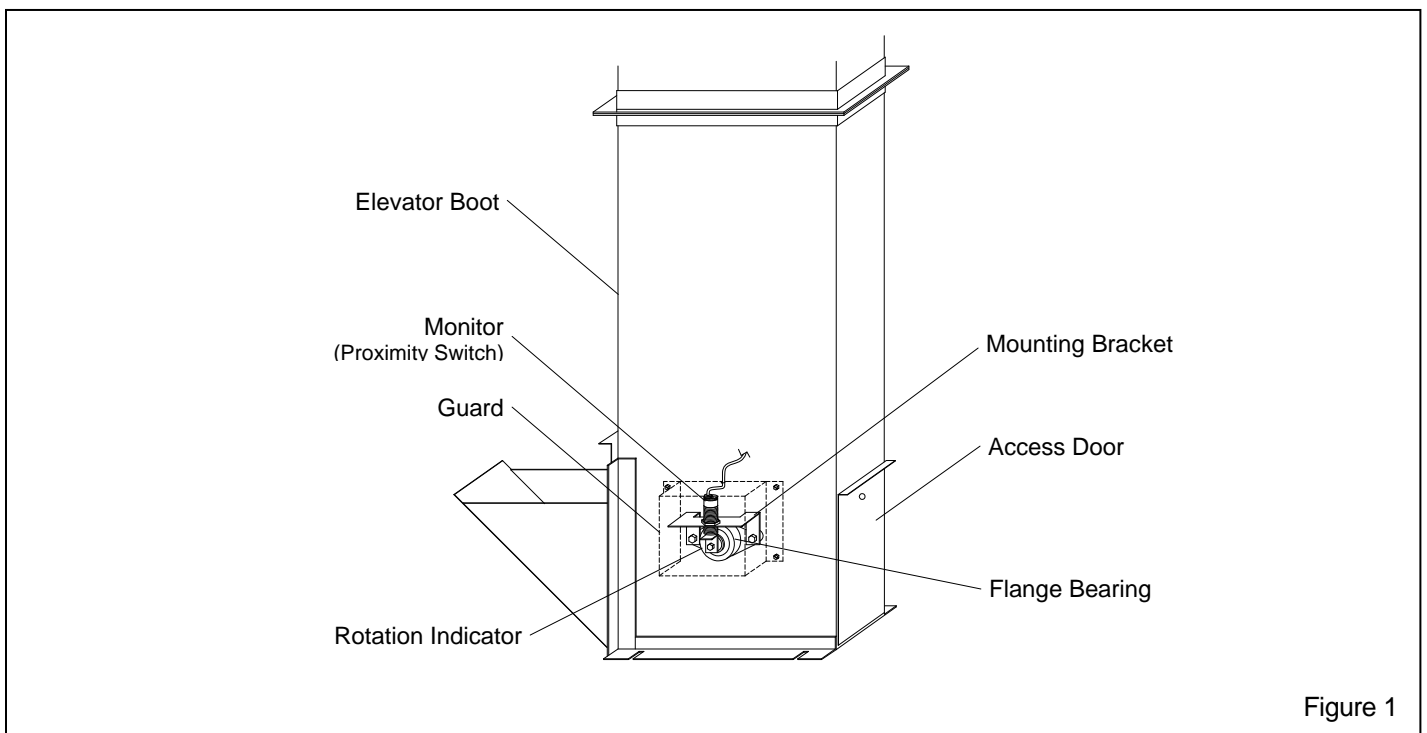

Figure 1

2.0 INSTALLATION
Refer to Figure 2

⚠ WARNING

Lockout and tagout electrical power before beginning the installation. Failure to do so could result in serious injury or death from electrical shock. Failure to lockout and tagout power enables unexpected starting of the elevator, causing severe injury if limbs or objects are caught or pinched in moving parts of the elevator.

2.1 Remove the elevator boot access door to reach the flange bearing mounting screw heads.

2.2 When replacing an old style monitor, remove the old proximity switch, mounting bracket, and rotation indicator from the lower elevator shaft, and the timer from the 8-pin socket located in the electric control panel. The socket will be reused for the new relay.

NOTE: The shaft on new elevators and replacement shafts are pre-drilled and tapped; steps in Paragraphs 2.3 and 2.4 are not required if the shaft is predrilled.

2.3 Drill a 0.257" hole, 1-1/4" deep on the bottom pulley shaft centerline. This step is not required for replacement monitors.

2.4 Tap the hole to a depth of 1" with a 5/16-18 NC thread. This step is not required for replacement monitors.

2.5 Install the rotation indicator using the 5/16 hex head cap screw and lock washer. Tighten hand tight only.

2.6 Use existing fasteners to install the mounting bracket on the flange bearing. Tighten securely.

2.7 Install the monitor onto the bracket as shown.

2.8 Rotate the bottom pulley or rotation indicator tab until the tab is facing the monitor as shown in figure 3.

2.9 Adjust the two nuts on the monitor so the distance between the monitor end and indicator tab is approximately 1/16", or as close as possible without touching, and a maximum gap of 1/8", as shown in Figure 3.

2.10 Tighten the adjusting nuts on the monitor, and the cap screw holding the rotation indicator.

2.11 Recheck the gap; make sure it is approximately 1/16" and that the rotation indicator tab clears the monitor as it moves pass.

2.12 Place the guard over the monitor as shown in Figure 1. If the elevator boot does not have mounting holes, hold the guard in position and match drill the holes.

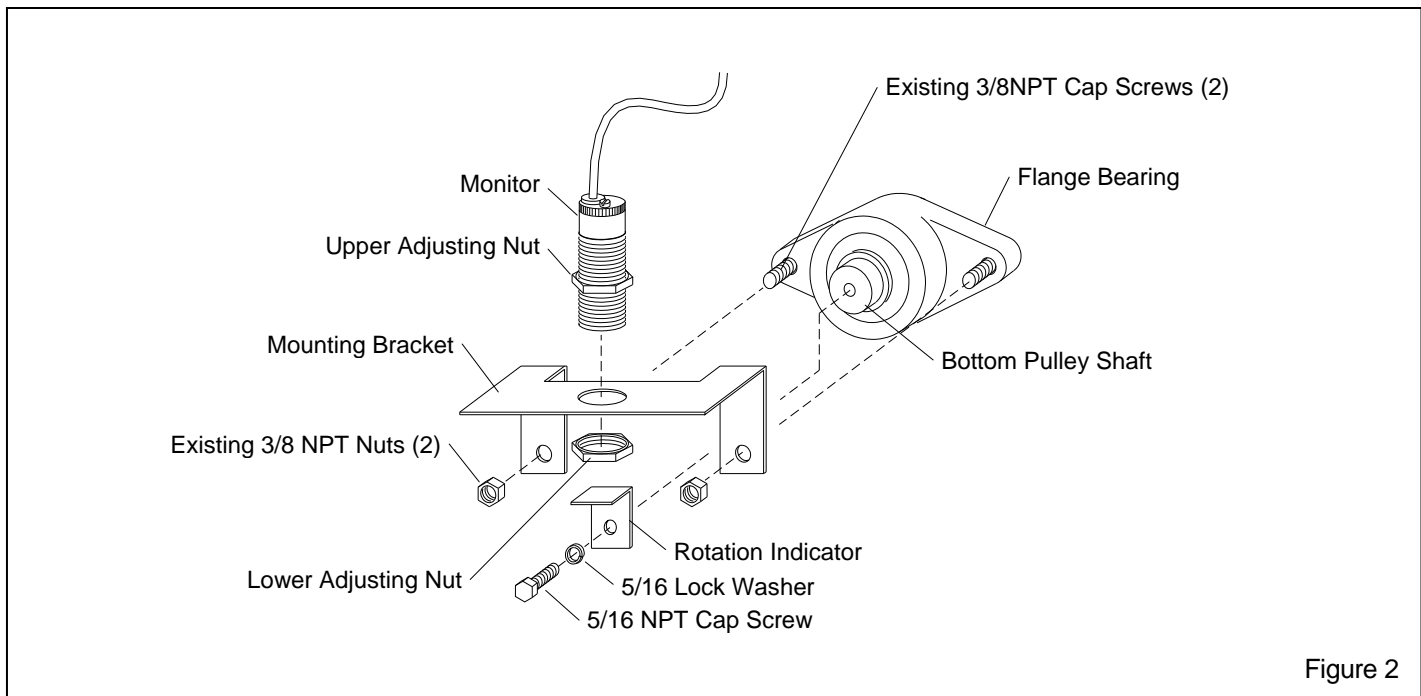

Figure 2

2.13 After the wiring is completed, and adjustments described in section 4.0 are completed, use sheet metal screws to attach the guard. Make sure the monitor lead cord goes through the hole in the top of the guard and that it is not pinched.

2.14 Install the bucket elevator access door.

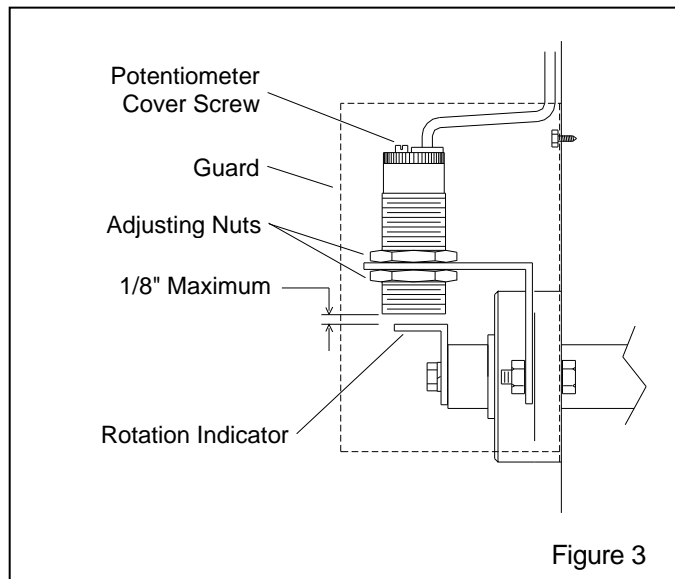

Figure 3

3.0 WIRING

CAUTION

The maximum load rating for the monitor is 0.2 amps. Damage to the monitor will occur if the load rating is exceeded. The monitor must be wired through a relay, not directly to the motor coil.

3.1 Run separate conduit for the monitor lead.

3.2 Wire the monitor to the elevator motor coil relay as shown in the wiring schematic with the job, or as shown in Figure 4 on Page 4. **NOTE: If other recovery components are used in conjunction with the bucket elevator, the monitor should be wired to shut-down the entire system. Doing so will prevent overloading any component if the elevator shuts-down.**

4.0 POTENTIOMETER ADJUSTMENT

4.1 The potentiometer adjusts the time-delay from when the indicator passes the monitor and the elevator shuts-down.

4.2 To gain access to the potentiometer, remove the cover screw located next to the lead cord entry point.

4.3 Using the special screwdriver provided, turn the potentiometer 20 full turns counter-clockwise. If the screwdriver is misplaced, use a small screw driver that is no wider than 3/32".

4.4 Start the elevator. Gradually turn the potentiometer clockwise until the elevator shuts down.

4.5 Turn the potentiometer only a few degrees counter-clockwise. Start the elevator and let it run for approximately one minute, and then turn the potentiometer very slowly clockwise until the elevator shuts down. Then, slowly turn the potentiometer from run to shutdown several times to find the trip point. A slipping belt should trip the switch, for that reason the setting should be no higher than needed to keep the elevator running.

4.6 Install the potentiometer cover screw.

5.0 REPLACEMENT PARTS

Item	Description	Stock No.
(-)	Underspeed Monitor Assembly	20217
1.	Monitor ,integrated prox.	21365
2.	Rotation indicator	21369
3.	Mounting bracket.....	21366
4.	Socket, 8 pin.....	12164
5.	Guard.....	21367
6.	Relay, 120 v, dpdt	12046

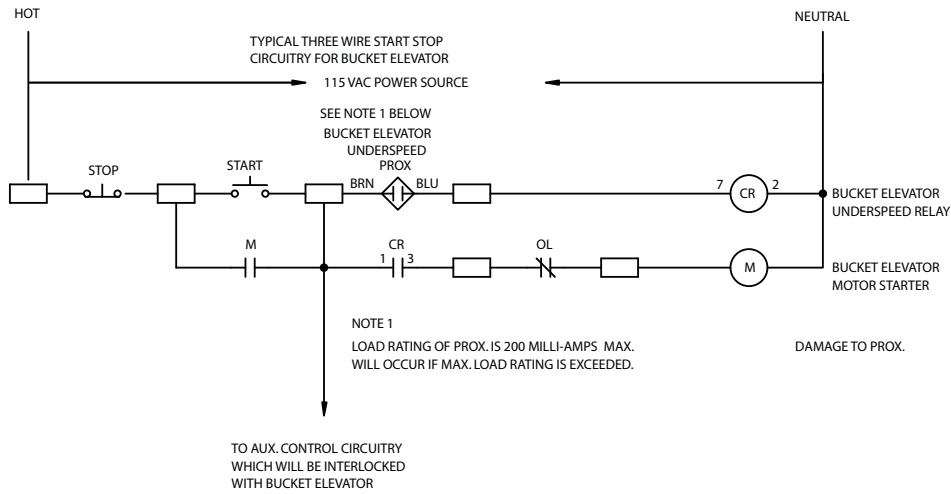

ITEM	STOCK NO.	DESCRIPTION	QUAN.
CUSTOMER PROVIDED ITEMS			
M		MOTOR STARTER	REF
OL		OVERLOAD FOR MOTOR STARTER	REF
START PB		NORMALLY OPEN FLUSH PUSH BUTTON	REF
STOP PB		NORMALLY CLOSED RED EXTENDED HEAD PB	REF
TERMINALS		TERMINALS PER CUSTOMER APPLICATION	REF

ITEMS PROVIDED WITH BUCKET ELEVATOR			
PROX.	21365	UNDERSPEED PROX	1
RELAY SOC.	12164	8 PIN RELAY SOCKET OCTAL	1
CR	12046	2 POLE DOUBLE THROW 120VAC OCTAL RELAY	1









SYMBOLS	DISCRIPTIONS
 BUCKET ELEVATOR UNDERSPEED PROX.	BUCKET ELEVATOR UNDERSPEED PROX. PROVIDED WITH BUCKET ELEVATOR NOTE: UNDERSPEED PROX. MUST ALWAYS BE WIRED ONLY TO RELAY COIL. LOAD RATING OF PROX. IS 200 MILLI-AMPS MAX. WILL OCCUR IF MAX. LOAD RATING IS EXCEEDED. DAMAGE TO PROX.
 STOP	NORMALLY CLOSED RED EXTENDED HEAD PUSH BUTTON PROVIDED BY CUSTOMER.
 START	NORMALLY OPEN GREEN OR BLACK FLUSH HEAD PUSH BUTTON PROVIDED BY CUSTOMER.
 7 2 CR	2 POLE DOUBLE THROW OCTAL 8PIN RELAY 120VAC 8 PIN OCTAL RELAY SOCKET PROVIDED ON ELEVATOR
 CR 1 3	NORMALLY OPEN CONTACT PART OF CR RELAY
 M	NORMALLY OPEN CONTACT PART OF M MOTOR STARTER
 M	COIL TO MOTOR STARTER FOR BUCKET ELEVATOR. PROVIDED BY CUSTOMER.
 OL	MOTOR STARTER OVERLOAD RELAY CONTACT. OVERLOAD RELAY NORMALLY LOACTED ON STARTER. HEATER FOR OVERLOAD SHOULD BE SIZED ACCORDING TO NFPA 70, 1993 NATIONAL ELECTRICAL CODE, ARTICLE 430
	TERMINALS PROVIDED BY CUSTOMERS

Figure 4