



POP-UP VALVE UMBRELLA (INSTALLATION INSTRUCTIONS)

1.0 INTRODUCTION

1.1 Scope: These instructions cover the field installation of Clemco 02318 bolt-on pop-up valve umbrella assembly. Do not attempt to install the umbrella on any machine that does not have supporting bosses cast into the pop-up valve seat casting.

!WARNING

Do not weld the umbrella to the blast machine. Do not drill into a blast machine that does not have supporting bosses cast into the pop-up valve seat casting.

!WARNING

Drilling into any part of the blast machine other than the supporting bosses, or any welding could weaken the vessel, resulting in death or serious injury. It also voids the National Board approval.

2.0 INSTALLATION

2.1 Shut off the air supply to the blast machine and ensure that the machine is not pressurized.

2.2 Identify the dimple in the center of each of the three seat casting bosses.

2.3 Cover the pop-up opening to prevent drill shavings from entering the blast machine.

2.4 Using the dimple as a center, drill a 13/64" diameter hole 5/8" deep in each boss.

2.5 Tap each hole with a 1/4"-20 (NC) thread.

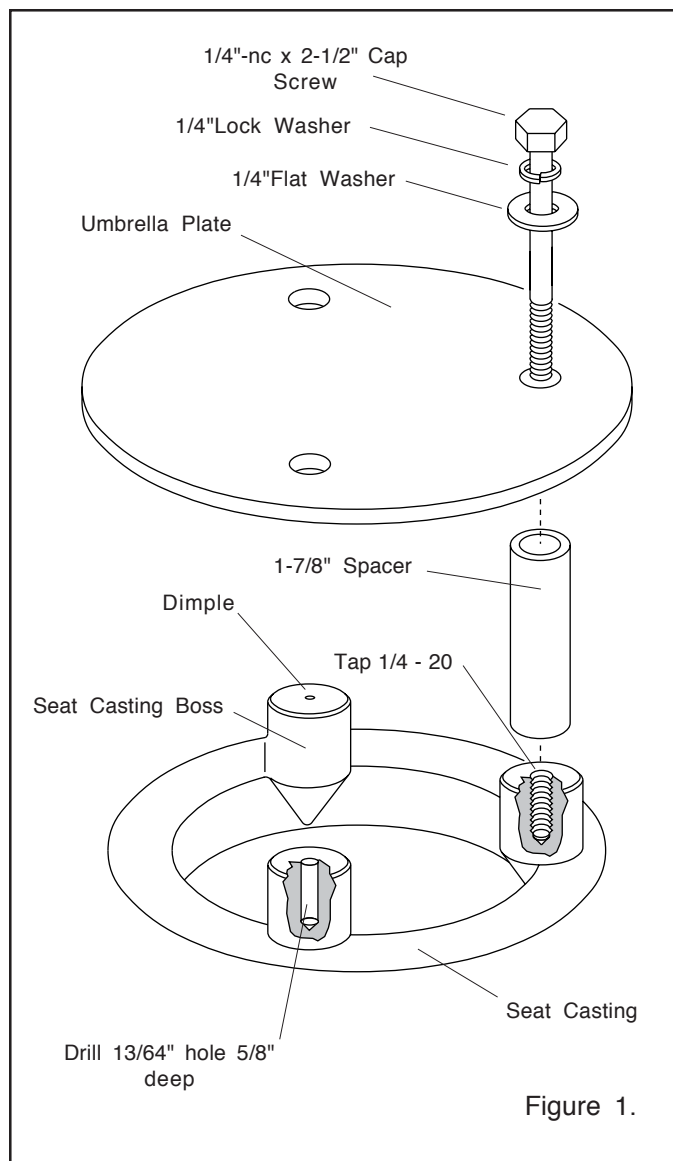

Figure 1.

2.6 Place a lock washer and a flat washer on the 1/4-nc x 2-1/2" cap screws.

2.7 Place the cap screw through the umbrella and spacer as shown in the illustration, and hand tighten.

2.8 Finish tightening each cap screw after all are hand installed.